



REVISION HISTORY

<u>Revision</u>	<u>Description</u>	<u>Issue Date</u>
Rev. 1.0	Initial Issue	Jul.12.2012
Rev. 1.1	"CE# $\geq V_{CC} - 0.2V$ " revised as "CE# $\leq 0.2V$ " for TEST CONDITION of Average Operating Power supply Current I_{CC1} on page3	Jul.19.2012
Rev. 1.2	Revised $V_{IH(max)}/V_{IL(min)}$ in <u>DC ELECTRICAL CHARACTERISTICS</u> Added in $t_{BA}/t_{BHZ}/t_{BLZ}$ in <u>AC ELECTRICAL CHARACTERISTICS</u>	May.07.2013
Rev. 1.3	Added WRITE CYCLE 3 in <u>TIMING WAVEFORMS</u> 1.Revise " TEST CONDITION " for V_{OH} , V_{OL} on page 5 $I_{OH} = -8mA$ revised as $-4mA$ $I_{OL} = 4mA$ revised as $8mA$ 2. Revise $V_{IH(max)}$ & $V_{IL(min)}$ note on page 5 $V_{IH(max)} = V_{CC} + 2.0V$ for pulse width less than 6ns. $V_{IL(min)} = V_{SS} - 2.0V$ for pulse width less than 6ns.	Jun.04.2013
Rev. 1.4	Revised the address pin sequence of TSOP II pin configuration on page 3 in order to be compatible with industry convention. (No function specifications and applications have been changed and all the characteristics are kept all the same as Rev 1.3) Added t_{BW} in <u>AC ELECTRICAL CHARACTERISTICS</u> Revised WRITE CYCLE 1,2 in <u>TIMING WAVEFORMS</u>	Sep.23.2013
Rev. 1.5	Added LY61L25616AGL-8I/-8IT in <u>ORDERING INFORMATION</u>	Jan.24.2014
Rev. 1.6	Revised <u>PIN DESCRIPTION</u> in page 1 Deleted C grade in <u>ORDERING INFORMATION</u> Deleted WRITE CYCLE Notes : 1. WE#,CE#, LB#, UB# must be high during all address transitions. in page 7.	Feb.13.2017

FEATURES

- Fast access time : 8/10/12ns
- **Low power consumption:**
 Operating current:
 50/40/35mA (TYP.)
 Standby current:
 2mA (TYP.)
- Single 3.3V power supply
- All inputs and outputs TTL compatible
- Fully static operation
- Tri-state output
- Data byte control : LB# (DQ0 ~ DQ7)
 UB# (DQ8 ~ DQ15)
- Data retention voltage : 1.5V (MIN.)
- **Green package available**
- Package : 44-pin 400mil TSOP II
 48-ball 6mm x 8mm TFBGA

GENERAL DESCRIPTION

The LY61L25616A is a 4,194,304-bit high speed CMOS static random access memory organized as 262,144 words by 16 bits. It is fabricated using very high performance, high reliability CMOS technology. Its standby current is stable within the range of operating temperature.

The LY61L25616A operates from a single power supply of 3.3V and all inputs and outputs are fully TTL compatible

PRODUCT FAMILY

Product Family	Operating Temperature	V _{CC} Range	Speed	Power Dissipation	
				Standby(I _{SB1} , TYP.)	Operating(I _{CC1} , TYP.)
LY61L25616A	0 ~ 70°C	2.7 ~ 3.6V	10/12ns	2mA	40/35mA
		3.0 ~ 3.6V	8ns	2mA	50mA
LY61L25616A(I)	-40 ~ 85°C	2.7 ~ 3.6V	10/12ns	2mA	40/35mA
		3.0 ~ 3.6V	8ns	2mA	50mA

FUNCTIONAL BLOCK DIAGRAM

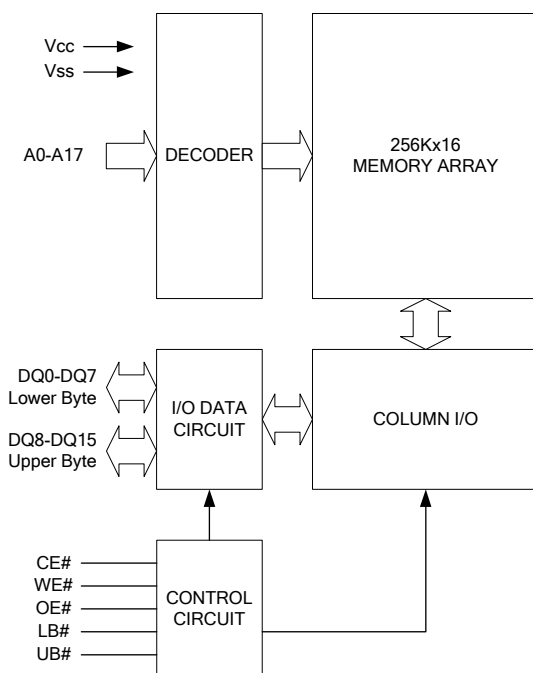

PIN DESCRIPTION

SYMBOL	DESCRIPTION
A0 - A17	Address Inputs
DQ0 - DQ15	Data Inputs/Outputs
CE#	Chip Enable Inputs
WE#	Write Enable Input
OE#	Output Enable Input
LB#	Lower Byte Control
UB#	Upper Byte Control
V _{CC}	Power Supply
V _{SS}	Ground
NC	No Connection



PIN CONFIGURATION

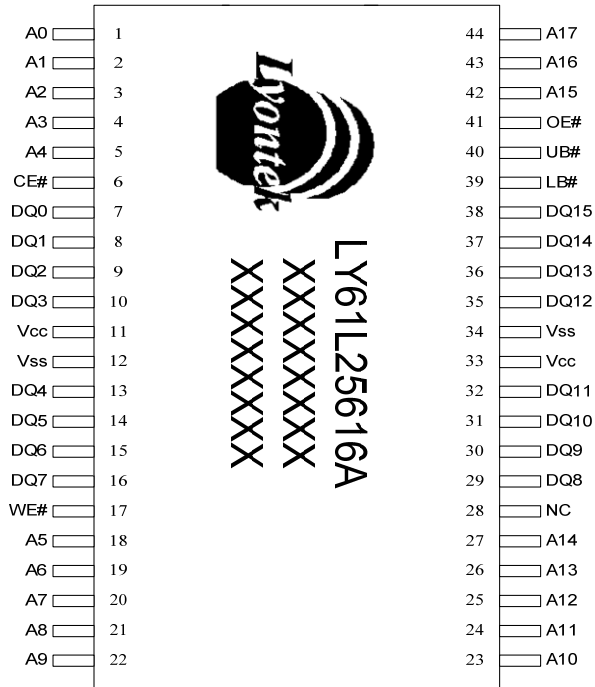

TSOP II

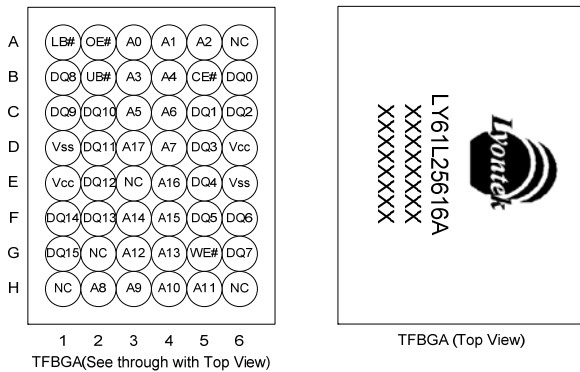

TFPGA(See through with Top View)

TFPGA (Top View)



ABSOLUTE MAXIMUM RATINGS*

PARAMETER	SYMBOL	RATING	UNIT
Voltage on V _{CC} relative to V _{SS}	V _{T1}	-0.5 to 4.6	V
Voltage on any other pin relative to V _{SS}	V _{T2}	-0.5 to V _{CC} +0.5	V
Operating Temperature	T _A	0 to 70(C grade)	°C
		-40 to 85(I grade)	
Storage Temperature	T _{STG}	-65 to 150	°C
Power Dissipation	P _D	1	W
DC Output Current	I _{OUT}	50	mA

*Stresses greater than those listed under "Absolute Maximum Ratings" may cause permanent damage to the device. This is a stress rating only and functional operation of the device or any other conditions above those indicated in the operational sections of this specification is not implied. Exposure to the absolute maximum rating conditions for extended period may affect device reliability.

TRUTH TABLE

MODE	CE#	OE#	WE#	LB#	UB#	I/O OPERATION		SUPPLY CURRENT
						DQ0 - DQ7	DQ8 - DQ15	
Standby	H	X	X	X	X	High-Z	High-Z	I _{SB} , I _{SB1}
Output Disable	L	H	H	X	X	High-Z	High-Z	I _{CC} , I _{CC1}
	L	X	X	H	H	High-Z	High-Z	
Read	L	L	H	L	H	D _{OUT}	High-Z	I _{CC} , I _{CC1}
	L	L	H	H	L	High-Z	D _{OUT}	
	L	L	H	L	L	D _{OUT}	D _{OUT}	
Write	L	X	L	L	H	D _{IN}	High-Z	I _{CC} , I _{CC1}
	L	X	L	H	L	High-Z	D _{IN}	
	L	X	L	L	L	D _{IN}	D _{IN}	

Note: H = V_{IH}, L = V_{IL}, X = Don't care



DC ELECTRICAL CHARACTERISTICS

PARAMETER	SYMBOL	TEST CONDITION	MIN.	TYP. ^{*4}	MAX.	UNIT	
Supply Voltage	V _{CC}		-8	3.0	3.3	3.6	V
			-10/-12	2.7	3.3	3.6	V
Input High Voltage	V _{IH} ^{*1}		2.2	-	V _{CC} +0.3	V	
Input Low Voltage	V _{IL} ^{*2}		- 0.3	-	0.8	V	
Input Leakage Current	I _{LI}	V _{CC} ≥ V _{IN} ≥ V _{SS}	- 1	-	1	μA	
Output Leakage Current	I _{LO}	V _{CC} ≥ V _{OUT} ≥ V _{SS} , Output Disabled	- 1	-	1	μA	
Output High Voltage	V _{OH}	I _{OH} = -4mA	2.4	-	-	V	
Output Low Voltage	V _{OL}	I _{OL} = 8mA	-	-	0.4	V	
Average Operating Power supply Current	I _{CC}	Cycle time = MIN. CE# = V _{IL} , I _{I/O} = 0mA, Others at V _{IL} or V _{IH}	-8	-	65	80	mA
			-10	-	50	70	mA
			-12	-	45	60	mA
	I _{CC1}	CE# ≤ 0.2, Others at 0.2V or V _{CC} -0.2V I _{I/O} = 0mA; f=MAX.	-8	-	50	60	mA
			-10	-	40	55	mA
			-12	-	35	50	mA
Standby Power Supply Current	I _{SB}	CE# = V _{IH} , Others at V _{IL} or V _{IH}	-	-	30	mA	
	I _{SB1}	CE# ≥ V _{CC} - 0.2V, Others at 0.2V or V _{CC} - 0.2V	-	2	10	mA	

Notes:

1. V_{IH}(max) = V_{CC} + 2.0V for pulse width less than 6ns.2. V_{IL}(min) = V_{SS} - 2.0V for pulse width less than 6ns.

3. Over/Undershoot specifications are characterized on engineering evaluation stage, not for mass production test.

4. Typical values are included for reference only and are not guaranteed or tested.

Typical values are measured at V_{CC} = V_{CC}(TYP.) and T_A = 25°C

CAPACITANCE (T_A = 25°C, f = 1.0MHz)

PARAMETER	SYMBOL	MIN.	MAX.	UNIT
Input Capacitance	C _{IN}	-	8	pF
Input/Output Capacitance	C _{I/O}	-	10	pF

Note : These parameters are guaranteed by device characterization, but not production tested.

AC TEST CONDITIONS

Speed	8/10/12ns
Input Pulse Levels	0.2V to V _{CC} - 0.2V
Input Rise and Fall Times	3ns
Input and Output Timing Reference Levels	1.5V
Output Load	C _L = 30pF + 1TTL, I _{OH} /I _{OL} = -4mA/8mA

Lyontek Inc. reserves the rights to change the specifications and products without notice.

2F, No. 17, Industry E. Rd. II, Science-Based Industrial Park, Hsinchu 300, Taiwan.

TEL: 886-3-6668838

FAX: 886-3-6668836



AC ELECTRICAL CHARACTERISTICS

(1) READ CYCLE

PARAMETER	SYM.	LY61L25616A-8		LY61L25616A-10		LY61L25616A-12		UNIT
		MIN.	MAX.	MIN.	MAX.	MIN.	MAX.	
Read Cycle Time	t _{RC}	8	-	10	-	12	-	ns
Address Access Time	t _{AA}	-	8	-	10	-	12	ns
Chip Enable Access Time	t _{ACE}	-	8	-	10	-	12	ns
Output Enable Access Time	t _{OE}	-	4.5	-	4.5	-	5	ns
Chip Enable to Output in Low-Z	t _{CLZ} *	2	-	2	-	3	-	ns
Output Enable to Output in Low-Z	t _{OLZ} *	0	-	0	-	0	-	ns
Chip Disable to Output in High-Z	t _{CHZ} *	-	3	-	4	-	5	ns
Output Disable to Output in High-Z	t _{OHZ} *	-	3	-	4	-	5	ns
Output Hold from Address Change	t _{OH}	2	-	2	-	2	-	ns
LB#, UB# Access Time	t _{BA}	-	4.5	-	4.5	-	5	ns
LB#, UB# to High-Z Output	t _{BHZ} *	-	3	-	4	-	5	ns
LB#, UB# to Low-Z Output	t _{BLZ} *	0	-	0	-	0	-	ns

(2) WRITE CYCLE

PARAMETER	SYM.	LY61L25616A-8		LY61L25616A-10		LY61L25616A-12		UNIT
		MIN.	MAX.	MIN.	MAX.	MIN.	MAX.	
Write Cycle Time	t _{WC}	8	-	10	-	12	-	ns
Address Valid to End of Write	t _{AW}	6.5	-	8	-	10	-	ns
Chip Enable to End of Write	t _{CW}	6.5	-	8	-	10	-	ns
Address Set-up Time	t _{AS}	0	-	0	-	0	-	ns
Write Pulse Width	t _{WP}	6.5	-	8	-	10	-	ns
Write Recovery Time	t _{WR}	0	-	0	-	0	-	ns
Data to Write Time Overlap	t _{DW}	5	-	6	-	7	-	ns
Data Hold from End of Write Time	t _{DH}	0	-	0	-	0	-	ns
Output Active from End of Write	t _{OW} *	2	-	2	-	2	-	ns
Write to Output in High-Z	t _{WHZ} *	-	3	-	4	-	5	ns
LB#, UB# Valid to End of Write	t _{BW}	6.5	-	8	-	10	-	ns

*These parameters are guaranteed by device characterization, but not production tested.



TIMING WAVEFORMS

READ CYCLE 1 (Address Controlled) (1,2)

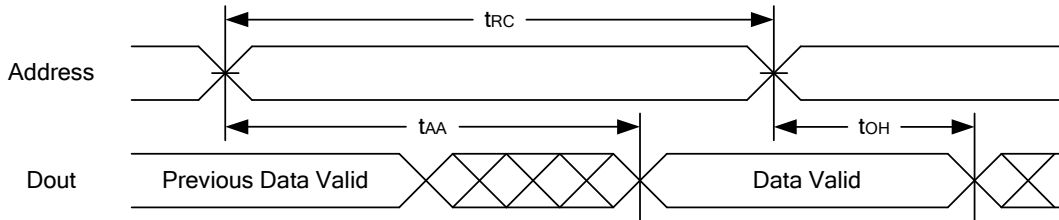

READ CYCLE 2 (CE# and OE# Controlled) (1,3,4,5)

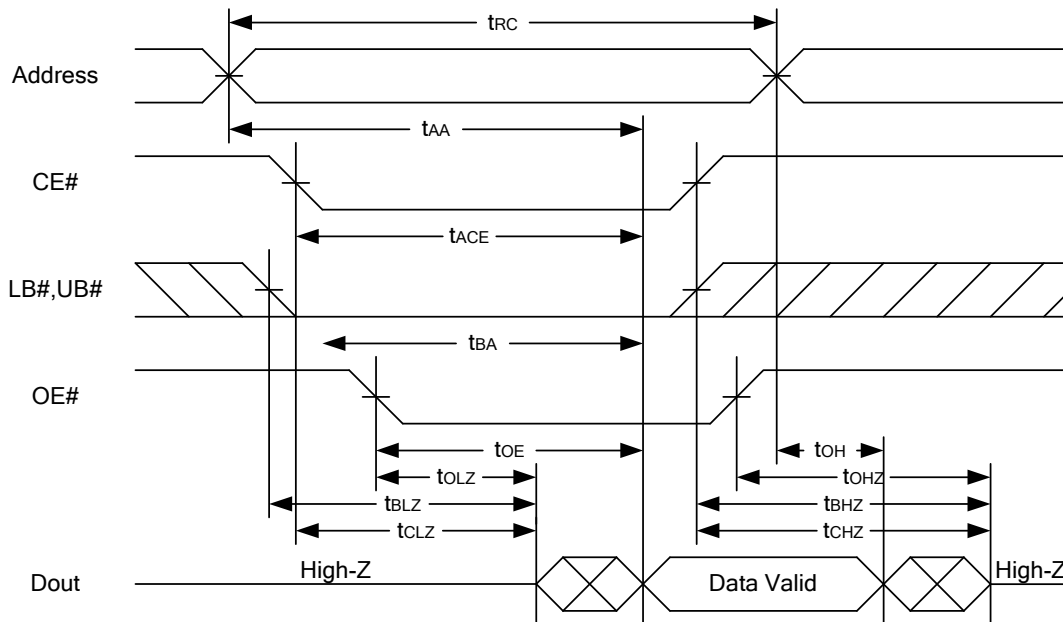

Notes :

1. WE# is high for read cycle.
2. Device is continuously selected OE# = low, CE# = low, LB# or UB# = low.
3. Address must be valid prior to or coincident with CE# = low, LB# or UB# = low transition; otherwise t_{AA} is the limiting parameter.
4. t_{CLZ} , t_{BLZ} , t_{OLZ} , t_{CHZ} , t_{BHZ} and t_{OHZ} are specified with $C_L = 5pF$. Transition is measured $\pm 500mV$ from steady state.
5. At any given temperature and voltage condition, t_{CHZ} is less than t_{CLZ} , t_{BHZ} is less than t_{BLZ} , t_{OHZ} is less than t_{OLZ}



WRITE CYCLE 1 (WE# Controlled) (1,2,4,5)

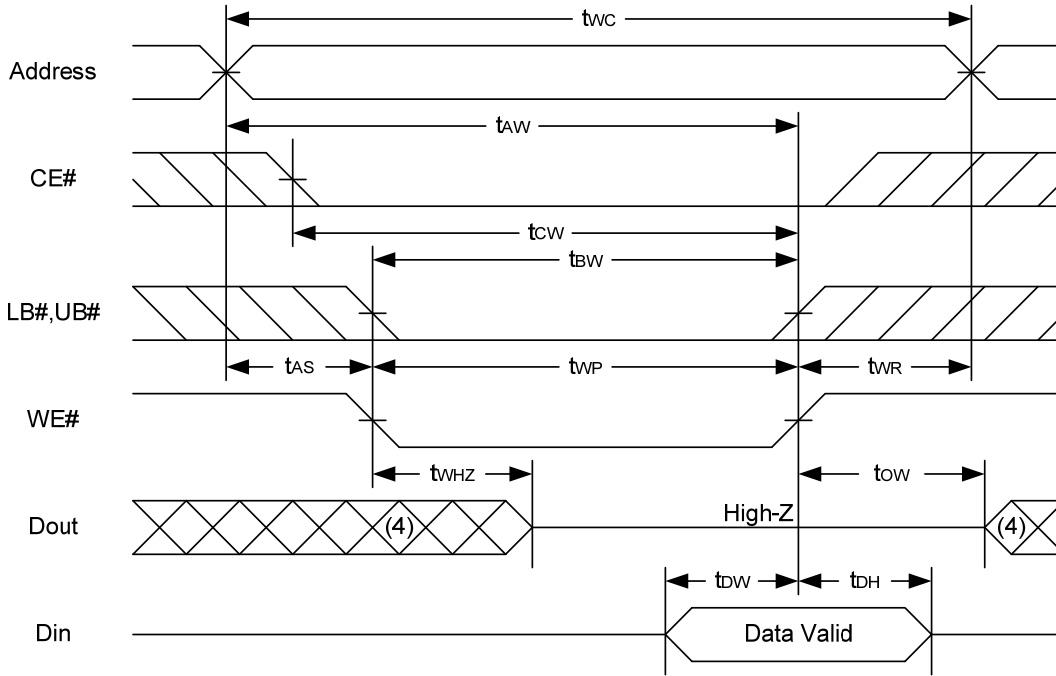

WRITE CYCLE 2 (CE# Controlled) (1,4,5)

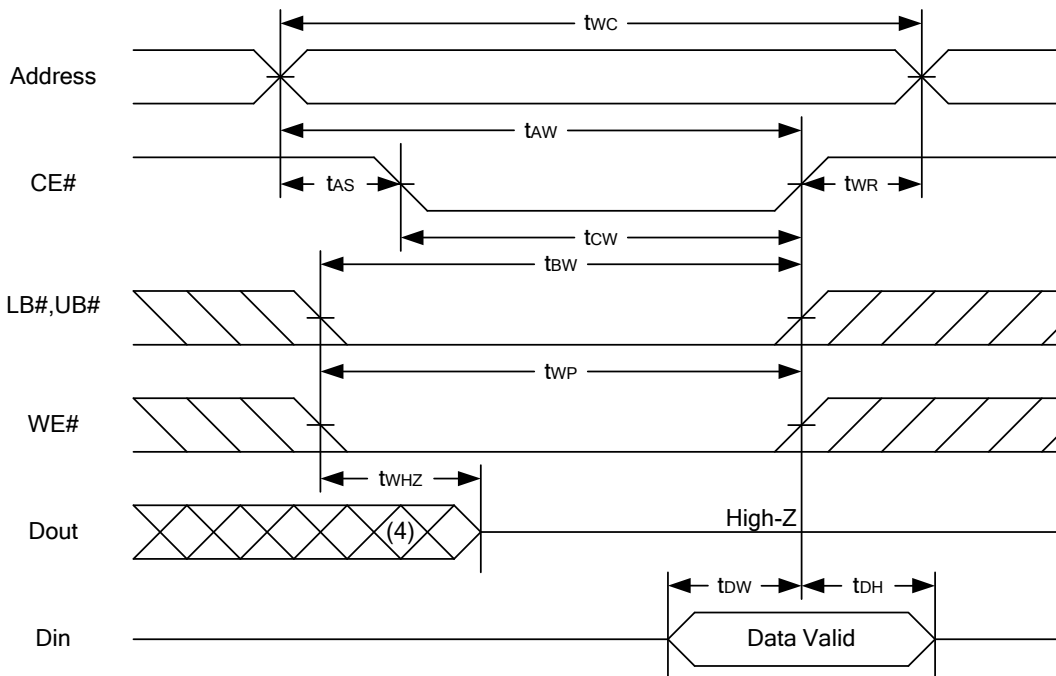



WRITE CYCLE 3 (LB#,UB# Controlled) (1,4,5)

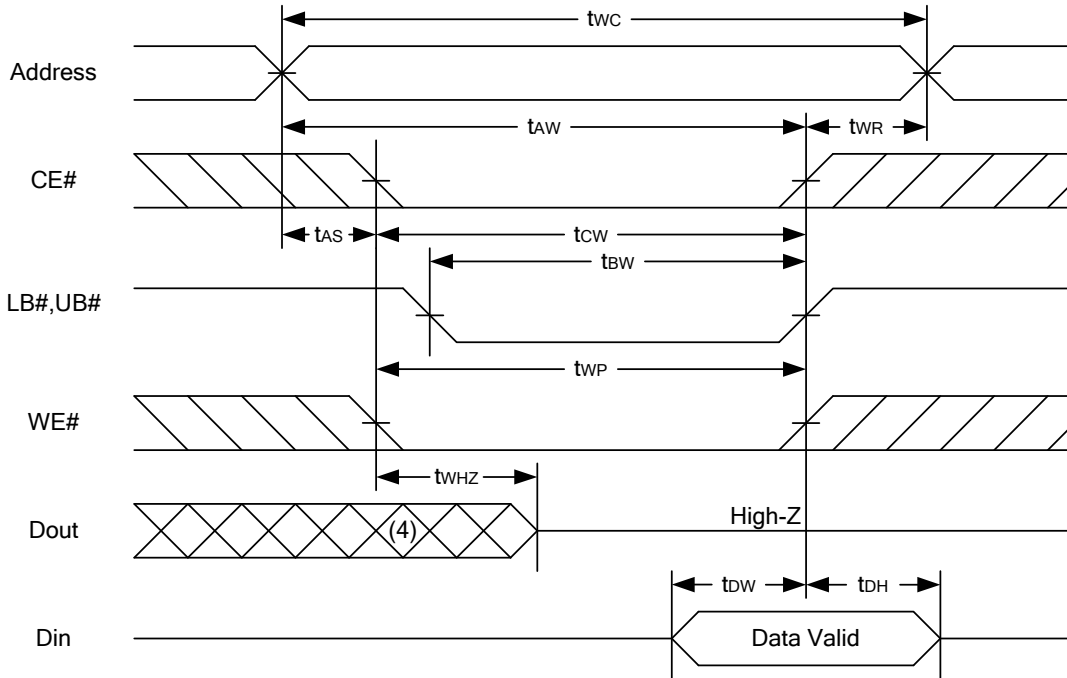

Notes :

1. A write occurs during the overlap of a low CE#, low WE#, LB# or UB# = low.
2. During a WE# controlled write cycle with OE# low, t_{WP} must be greater than $t_{WHZ} + t_{DW}$ to allow the drivers to turn off and data to be placed on the bus.
3. During this period, I/O pins are in the output state, and input signals must not be applied.
4. If the CE#, LB#, UB# low transition occurs simultaneously with or after WE# low transition, the outputs remain in a high impedance state.
5. t_{OW} and t_{WHZ} are specified with $C_L = 5pF$. Transition is measured $\pm 500mV$ from steady state.



DATA RETENTION CHARACTERISTICS

PARAMETER	SYMBOL	TEST CONDITION	MIN.	TYP.	MAX.	UNIT
V _{CC} for Data Retention	V _{DR}	CE# ≥ V _{CC} - 0.2V	1.5	-	3.6	V
Data Retention Current	I _{DR}	V _{CC} = 1.5V, CE# ≥ V _{CC} - 0.2V Others at 0.2V or V _{CC} - 0.2V	-	2	10	mA
Chip Disable to Data Retention Time	t _{CDR}	See Data Retention Waveforms (below)	0	-	-	ns
Recovery Time	t _R		t _{RC} *	-	-	ns

t_{RC}* = Read Cycle Time

DATA RETENTION WAVEFORM

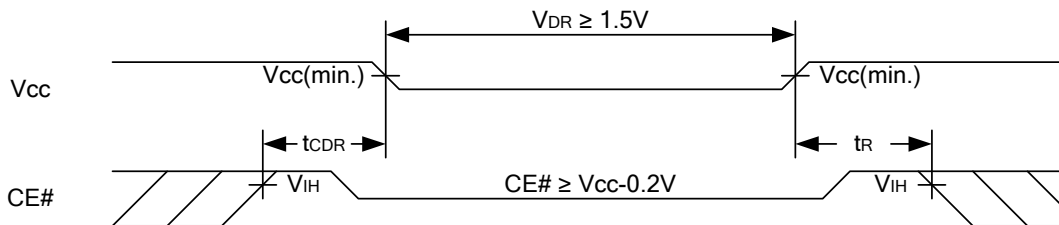



PACKAGE OUTLINE DIMENSION

44-pin 400 mil TSOP II Package Outline Dimension

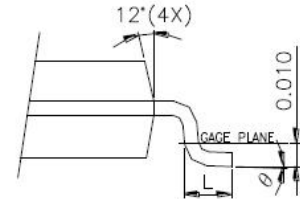
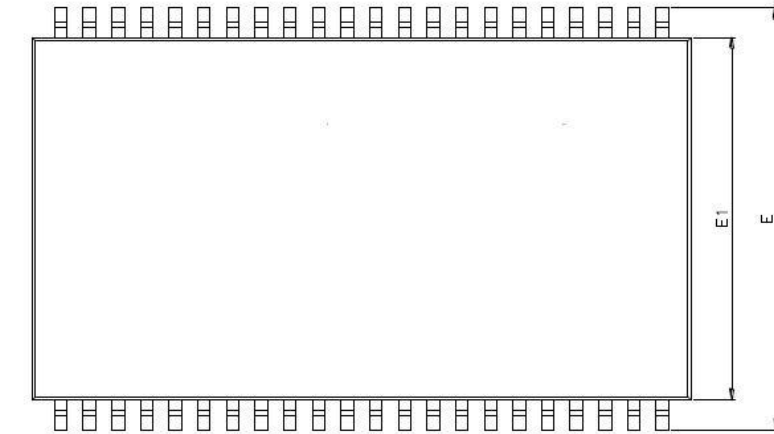

DETAIL B

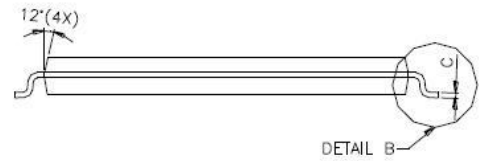
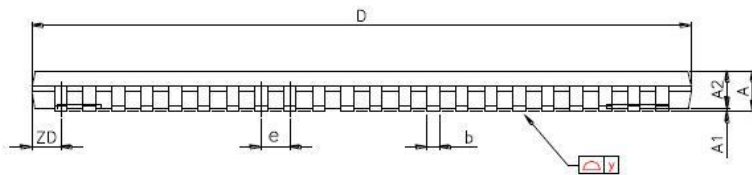

DETAIL B

SYMBOLS	DIMENSIONS IN MILLIMETERS			DIMENSIONS IN MILS		
	MIN.	NOM.	MAX.	MIN.	NOM.	MAX.
A	-	-	1.20	-	-	47.2
A1	0.05	0.10	0.15	2.0	3.9	5.9
A2	0.95	1.00	1.05	37.4	39.4	41.3
b	0.30	-	0.45	11.8	-	17.7
c	0.12	-	0.21	4.7	-	8.3
D	18.212	18.415	18.618	717	725	733
E	11.506	11.760	12.014	453	463	473
E1	9.957	10.160	10.363	392	400	408
e	-	0.800	-	-	31.5	-
L	0.40	0.50	0.60	15.7	19.7	23.6
ZD	-	0.805	-	-	31.7	-
y	-	-	0.076	-	-	3
θ	0°	3°	6°	0°	3°	6°

48-ball 6mm × 8mm TFBGA Package Outline Dimension

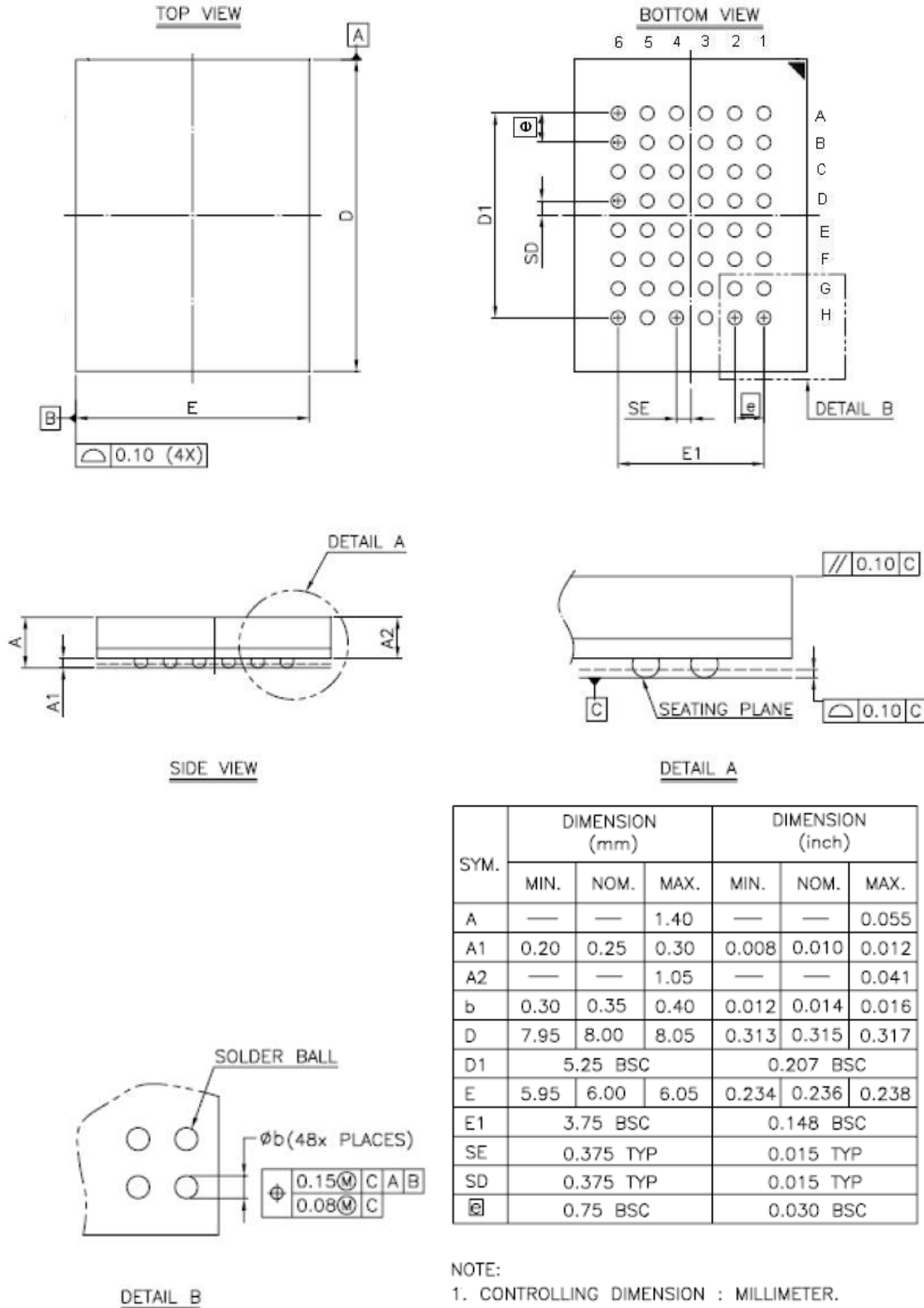



ORDERING INFORMATION

Package Type	Access Time (Speed/ns)	Temperature Range(°C)	Packing Type	Lyontek Item No.
44-pin (400mil) TSOP II	8	-40°C~85°C	Tray	LY61L25616AML-8I
			Tape Reel	LY61L25616AML-8IT
	10	-40°C~85°C	Tray	LY61L25616AML-10I
			Tape Reel	LY61L25616AML-10IT



ORDERING INFORMATION

Package Type	Access Time (Speed/ns)	Temperature Range(°C)	Packing Type	Lyontek Item No.
48-ball (6mm x 8mm) TFBGA	8	-40°C~85°C	Tray	LY61L25616AGL-8I
			Tape Reel	LY61L25616AGL-8IT
	10	-40°C~85°C	Tray	LY61L25616AGL-10I
			Tape Reel	LY61L25616AGL-10IT



Lyontek Inc.

LY61L25616A

Rev. 1.6

256K X 16 BIT HIGH SPEED CMOS SRAM

THIS PAGE IS LEFT BLANK INTENTIONALLY.