



### REVISION HISTORY

<u>Revision</u>	<u>Description</u>	<u>Issue Date</u>
Rev. 1.0	Initial Issue	Apr.06.2016
Rev. 1.1	Deleted <b>WRITE CYCLE</b> Notes : 1. WE#,CE#, LB#, UB# must be high or CE2 must be low during all address transitions. in page 8	Jun.28.2016
Rev. 1.2	Revised $I_{CC}$ / $I_{CC1}$ / $I_{SB1}(MAX.)$ / $I_{DR}(MAX.)$ in <b><u>DC ELECTRICAL CHARACTERISTICS &amp; DATA RETENTION CHARACTERISTICS &amp; PRODUCT FAMILY &amp; FEATURES</u></b>	Apr.07.2017
Rev. 1.3	Added <b><u>TRUTH TABLE</u></b> Notes: 2. The BYTE# pin has to be tied to $V_{CC}$ to use the device as a 4M x 16 SRAM, and to be tied to $V_{SS}$ as a 8M x 8 SRAM. In the 8M x 8 configuration, Pin 45 is A-1, and both UB# and LB# are tied to $V_{SS}$ , while DQ8 to DQ14 pins are not used.	May.22.2017
Rev. 1.4	Revised typo in <b><u>TIMING WAVEFORMS</u></b> of <b>WRITE CYCLE</b> in page 7 & 8	Jul.30.2020



#### FEATURES

- Fast access time : 55ns
- Low power consumption:  
Operating current : 12mA (TYP.)  
Standby current : 12 $\mu$ A(TYP.)
- Single 2.7V ~ 3.6V power supply
- All inputs and outputs TTL compatible
- Fully static operation
- Tri-state output
- Data byte control :
  - (i) BYTE# fixed to  $V_{CC}$   
LB# controlled DQ0 ~ DQ7  
UB# controlled DQ8 ~ DQ15
  - (ii) BYTE# fixed to  $V_{SS}$   
DQ15 used as address pin, while  
DQ8~DQ14 pins not used
- Data retention voltage : 1.2V (MIN.)
- **Green package available**
- Package : 48-pin 12mm x 20mm TSOP I

#### GENERAL DESCRIPTION

The LY62L409816A is a 67,108,864-bit low power CMOS static random access memory organized as 4,194,304 words by 16 bits or 8,388,608 words by 8 bits. It is fabricated using very high performance, high reliability CMOS technology. Its standby current is stable within the range of operating temperature.

The LY62L409816A is well designed for low power application, and particularly well suited for battery back-up nonvolatile memory application.

The LY62L409816A operates from a single power supply of 2.7V ~ 3.6V and all inputs and outputs are fully TTL compatible

#### PRODUCT FAMILY

Product Family	Operating Temperature	$V_{CC}$ Range	Speed	Power Dissipation	
				Standby( $I_{SB1}$ , TYP.)	Operating( $I_{CC}$ , TYP.)
LY62L409816A	0 ~ 70°C	2.7 ~ 3.6V	55ns	12 $\mu$ A	12mA
LY62L409816A(I)	-40 ~ 85°C	2.7 ~ 3.6V	55ns	12 $\mu$ A	12mA



### FUNCTIONAL BLOCK DIAGRAM

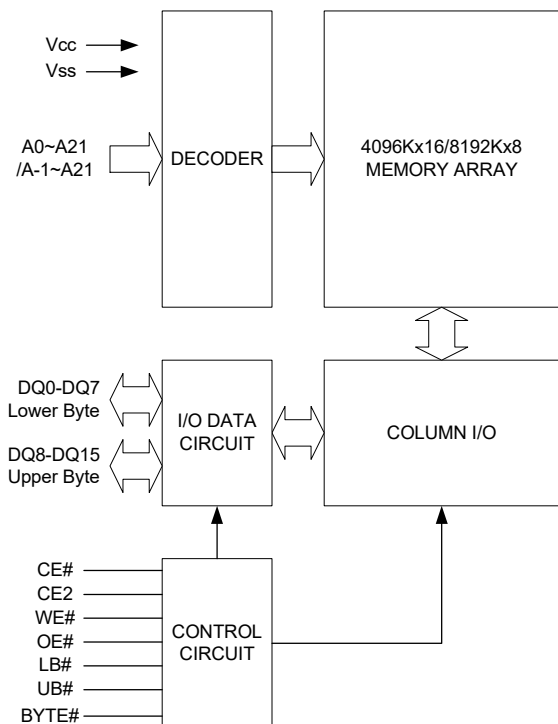

### PIN DESCRIPTION

SYMBOL	DESCRIPTION
A0 - A21	Address Inputs(word mode)
A-1 - A21	Address Inputs(byte mode)
DQ0 - DQ15	Data Inputs/Outputs
CE#, CE2	Chip Enable Input
WE#	Write Enable Input
OE#	Output Enable Input
LB#	Lower Byte Control
UB#	Upper Byte Control
BYTE#	Byte Enable
Vcc	Power Supply
Vss	Ground

### PIN CONFIGURATION



TSOP I

Lyontek Inc. reserves the rights to change the specifications and products without notice.

2F, No.17, Industry E. Rd. II, Science-Based Industrial Park, Hsinchu 300, Taiwan.

TEL: 886-3-6668838

FAX: 886-3-6668836



#### ABSOLUTE MAXIMUM RATINGS\*

PARAMETER	SYMBOL	RATING	UNIT
Voltage on V <sub>CC</sub> relative to V <sub>SS</sub>	V <sub>T1</sub>	-0.5 to 4.6	V
Voltage on any other pin relative to V <sub>SS</sub>	V <sub>T2</sub>	-0.5 to V <sub>CC</sub> +0.5	V
Operating Temperature	T <sub>A</sub>	0 to 70(C grade)	°C
		-40 to 85(I grade)	
Storage Temperature	T <sub>STG</sub>	-65 to 150	°C
Power Dissipation	P <sub>D</sub>	1	W
DC Output Current	I <sub>OUT</sub>	50	mA

\*Stresses greater than those listed under "Absolute Maximum Ratings" may cause permanent damage to the device. This is a stress rating only and functional operation of the device or any other conditions above those indicated in the operational sections of this specification is not implied. Exposure to the absolute maximum rating conditions for extended period may affect device reliability.

#### TRUTH TABLE

MODE	CE#	CE2	BYTE #	OE#	WE#	LB#	UB#	I/O OPERATION			SUPPLY CURRENT
								DQ0-DQ7	DQ8-DQ14	DQ15	
Standby	H	X	X	X	X	X	X	High-Z	High-Z	High-Z	I <sub>SB1</sub>
	X	L	X	X	X	X	X	High-Z	High-Z	High-Z	
	X	X	H	X	X	H	H	High-Z	High-Z	High-Z	
Output Disable	L	H	H	H	H	L	X	High-Z	High-Z	High-Z	I <sub>CC</sub> , I <sub>CC1</sub>
	L	H	H	H	H	X	L	High-Z	High-Z	High-Z	
	L	H	L	H	H	L	L	High-Z	High-Z	A-1	
Read	L	H	H	L	H	L	H	D <sub>OUT</sub>	High-Z	High-Z	I <sub>CC</sub> , I <sub>CC1</sub>
	L	H	H	L	H	H	L	High-Z	D <sub>OUT</sub>	D <sub>OUT</sub>	
	L	H	H	L	H	L	L	D <sub>OUT</sub>	D <sub>OUT</sub>	D <sub>OUT</sub>	
Write	L	H	H	X	L	L	H	D <sub>IN</sub>	High-Z	High-Z	I <sub>CC</sub> , I <sub>CC1</sub>
	L	H	H	X	L	H	L	High-Z	D <sub>IN</sub>	D <sub>IN</sub>	
	L	H	H	X	L	L	L	D <sub>IN</sub>	D <sub>IN</sub>	D <sub>IN</sub>	
Byte# Read	L	H	L	L	H	L	L	D <sub>OUT</sub>	High-Z	A-1	I <sub>CC</sub> , I <sub>CC1</sub>
Byte # Write	L	H	L	X	L	L	L	D <sub>IN</sub>	High-Z	A-1	I <sub>CC</sub> , I <sub>CC1</sub>

Notes:

- H = V<sub>IH</sub>, L = V<sub>IL</sub>, X = Don't care.
- The BYTE# pin has to be tied to V<sub>CC</sub> to use the device as a 4M x 16 SRAM, and to be tied to V<sub>SS</sub> as a 8M x 8 SRAM. In the 8M x 8 configuration, Pin 45 is A-1, and both UB# and LB# are tied to V<sub>SS</sub>, while DQ8 to DQ14 pins are not used.



#### DC ELECTRICAL CHARACTERISTICS

PARAMETER	SYMBOL	TEST CONDITION	MIN.	TYP. <sup>*4</sup>	MAX.	UNIT	
Supply Voltage	V <sub>CC</sub>		2.7	3.0	3.6	V	
Input High Voltage	V <sub>IH</sub> <sup>*1</sup>		2.2	-	V <sub>CC</sub> +0.3	V	
Input Low Voltage	V <sub>IL</sub> <sup>*2</sup>		- 0.2	-	0.6	V	
Input Leakage Current	I <sub>LI</sub>	V <sub>CC</sub> ≥ V <sub>IN</sub> ≥ V <sub>SS</sub>	- 1	-	1	μA	
Output Leakage Current	I <sub>LO</sub>	V <sub>CC</sub> ≥ V <sub>OUT</sub> ≥ V <sub>SS</sub> Output Disabled	- 1	-	1	μA	
Output High Voltage	V <sub>OH</sub>	I <sub>OH</sub> = -1mA	2.2	2.7	-	V	
Output Low Voltage	V <sub>OL</sub>	I <sub>OL</sub> = 2mA	-	-	0.4	V	
Average Operating Power supply Current	I <sub>CC</sub>	Cycle time = MIN. CE# ≤ 0.2V and CE2 ≥ V <sub>CC</sub> -0.2V I <sub>I/O</sub> = 0mA Other pins at 0.2V or V <sub>CC</sub> -0.2V	-	12	20	mA	
	I <sub>CC1</sub>	Cycle time = 1μs CE# ≤ 0.2V and CE2 ≥ V <sub>CC</sub> -0.2V I <sub>I/O</sub> = 0mA Other pins at 0.2V or V <sub>CC</sub> -0.2V	-	3	5	mA	
Standby Power Supply Current	I <sub>SB1</sub>	CE# ≥ V <sub>CC</sub> -0.2V or CE2 ≤ 0.2V Other pins at 0.2V or V <sub>CC</sub> -0.2V	-SL <sup>*5</sup> 25°C	-	12	32	μA
			-SLI <sup>*5</sup> 40°C	-	12	36	μA
			-SL (70°C)	-	-	100	μA
			-SLI (85°C)	-	-	160	μA

Notes:

- V<sub>IH</sub>(max) = V<sub>CC</sub> + 2.0V for pulse width less than 6ns.
- V<sub>IL</sub>(min) = V<sub>SS</sub> - 2.0V for pulse width less than 6ns.
- Over/Undershoot specifications are characterized on engineering evaluation stage, not for mass production test.
- Typical values, measured at V<sub>CC</sub> = V<sub>CC</sub>(TYP.) and T<sub>A</sub> = 25°C, are included for reference only and are not guaranteed or tested.
- This parameter is measured at V<sub>CC</sub>=3.0V.

#### CAPACITANCE (T<sub>A</sub> = 25°C, f = 1.0MHz)

PARAMETER	SYMBOL	MIN.	MAX.	UNIT
Input Capacitance	C <sub>IN</sub>	-	15	pF
Input/Output Capacitance	C <sub>I/O</sub>	-	20	pF

Note : These parameters are guaranteed by device characterization, but not production tested.



### AC TEST CONDITIONS

Input Pulse Levels	0.2V to $V_{CC} - 0.2V$
Input Rise and Fall Times	3ns
Input and Output Timing Reference Levels	1.5V
Output Load	$C_L = 30pF + 1TTL, I_{OH}/I_{OL} = -1mA/2mA$

### AC ELECTRICAL CHARACTERISTICS

#### (1) READ CYCLE

PARAMETER	SYM.	LY62L409816A-55		UNIT
		MIN.	MAX.	
Read Cycle Time	$t_{RC}$	55	-	ns
Address Access Time	$t_{AA}$	-	55	ns
Chip Enable Access Time	$t_{ACE}$	-	55	ns
Output Enable Access Time	$t_{OE}$	-	30	ns
Chip Enable to Output in Low-Z	$t_{CLZ}^*$	10	-	ns
Output Enable to Output in Low-Z	$t_{OLZ}^*$	5	-	ns
Chip Disable to Output in High-Z	$t_{CHZ}^*$	-	20	ns
Output Disable to Output in High-Z	$t_{OHZ}^*$	-	20	ns
Output Hold from Address Change	$t_{OH}$	10	-	ns
LB#, UB# Access Time	$t_{BA}$	-	55	ns
LB#, UB# to High-Z Output	$t_{BHZ}^*$	-	20	ns
LB#, UB# to Low-Z Output	$t_{BLZ}^*$	10	-	ns

#### (2) WRITE CYCLE

PARAMETER	SYM.	LY62L409816A-55		UNIT
		MIN.	MAX.	
Write Cycle Time	$t_{WC}$	55	-	ns
Address Valid to End of Write	$t_{AW}$	50	-	ns
Chip Enable to End of Write	$t_{CW}$	50	-	ns
Address Set-up Time	$t_{AS}$	0	-	ns
Write Pulse Width	$t_{WP}$	45	-	ns
Write Recovery Time	$t_{WR}$	0	-	ns
Data to Write Time Overlap	$t_{DW}$	25	-	ns
Data Hold from End of Write Time	$t_{DH}$	0	-	ns
Output Active from End of Write	$t_{OW}^*$	5	-	ns
Write to Output in High-Z	$t_{WHZ}^*$	-	20	ns
LB#, UB# Valid to End of Write	$t_{BW}$	50	-	ns

\*These parameters are guaranteed by device characterization, but not production tested.



### TIMING WAVEFORMS

#### READ CYCLE 1 (Address Controlled) (1,2)

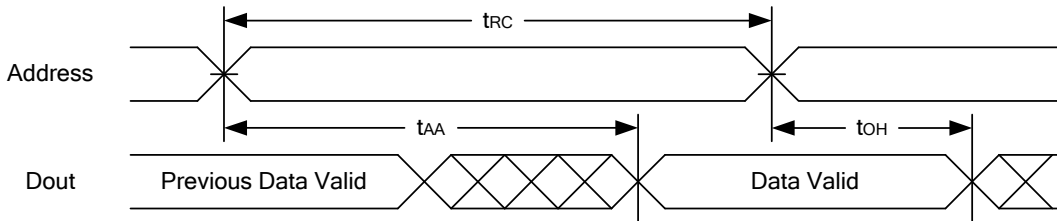

#### READ CYCLE 2 (CE# and CE2 and OE# Controlled) (1,3,4,5)

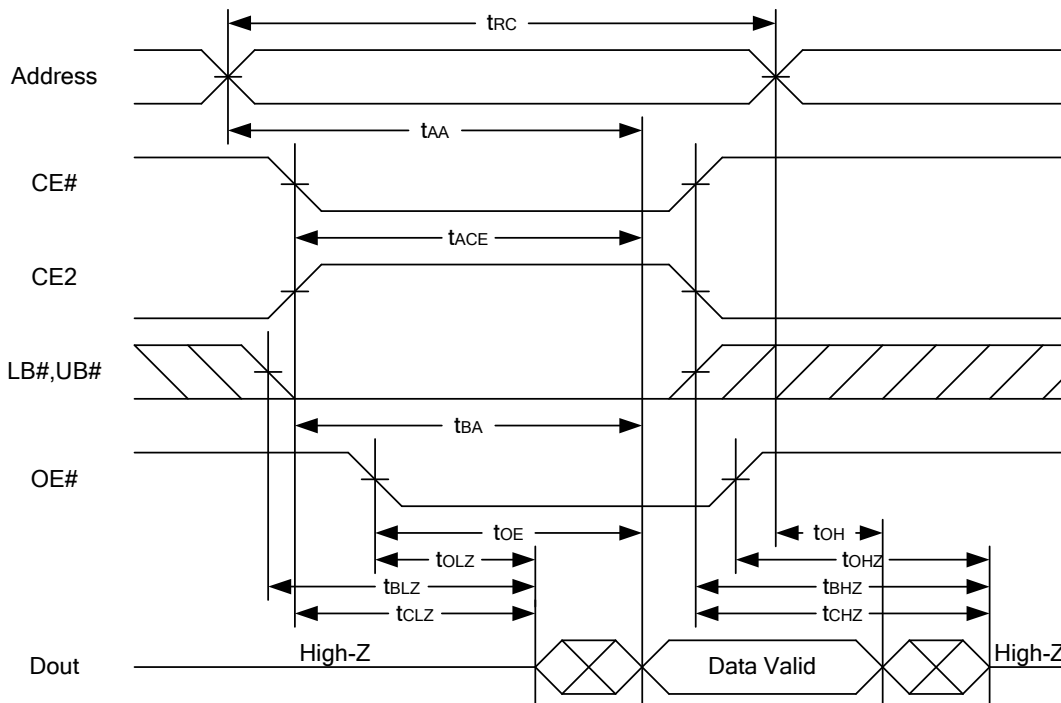

#### Notes :

1. WE# is high for read cycle.
2. Device is continuously selected OE# = low, CE# = low, CE2 = high, LB# or UB# = low.
3. Address must be valid prior to or coincident with CE# = low, CE2 = high, LB# or UB# = low transition; otherwise tAA is the limiting parameter.
4. tCLZ, tBLZ, tOLZ, tCHZ, tBHZ and tOHZ are specified with CL = 5pF. Transition is measured ±500mV from steady state.
5. At any given temperature and voltage condition, tCHZ is less than tCLZ, tBHZ is less than tBLZ, tOHZ is less than tOLZ.



#### WRITE CYCLE 1 (WE# Controlled) (1,2,4,5)

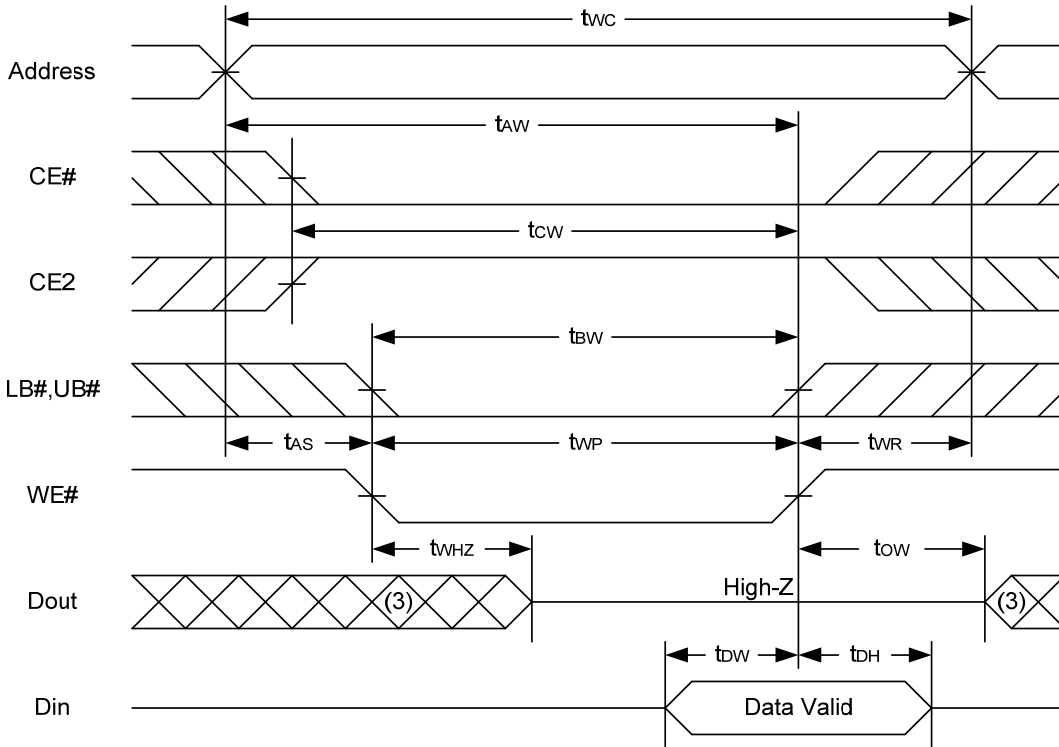

#### WRITE CYCLE 2 (CE# and CE2 Controlled) (1,4,5)

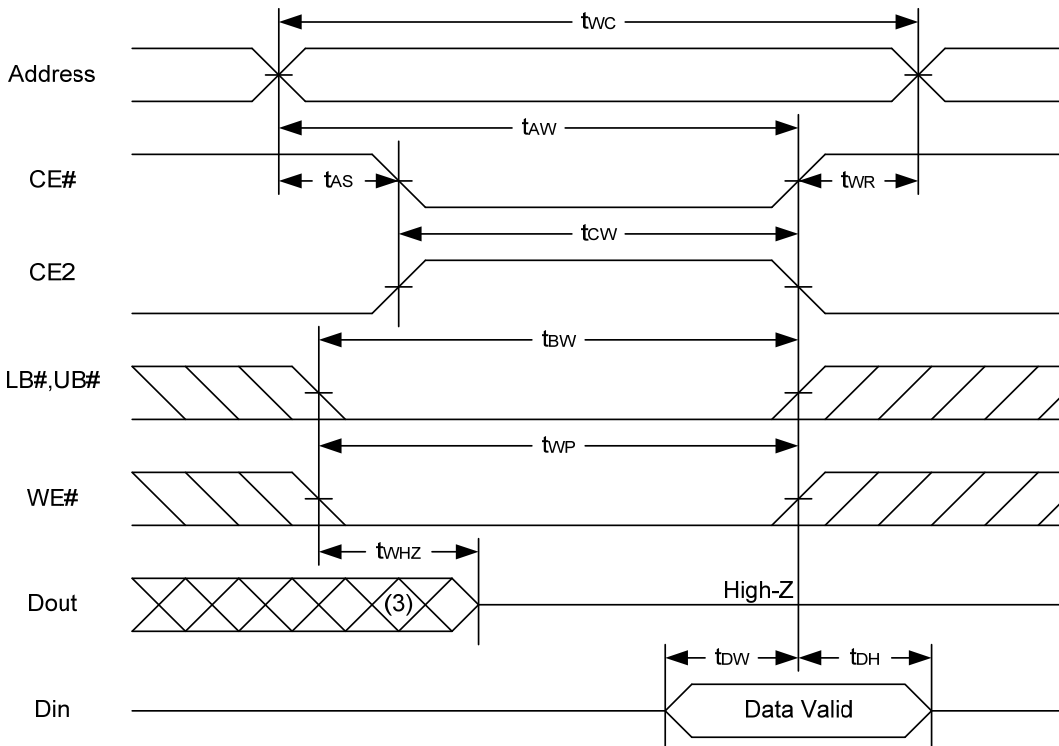

Lyontek Inc. reserves the rights to change the specifications and products without notice.

2F, No.17, Industry E. Rd. II, Science-Based Industrial Park, Hsinchu 300, Taiwan.

TEL: 886-3-6668838

FAX: 886-3-6668836





#### WRITE CYCLE 3 (LB#,UB# Controlled) (1,4,5)

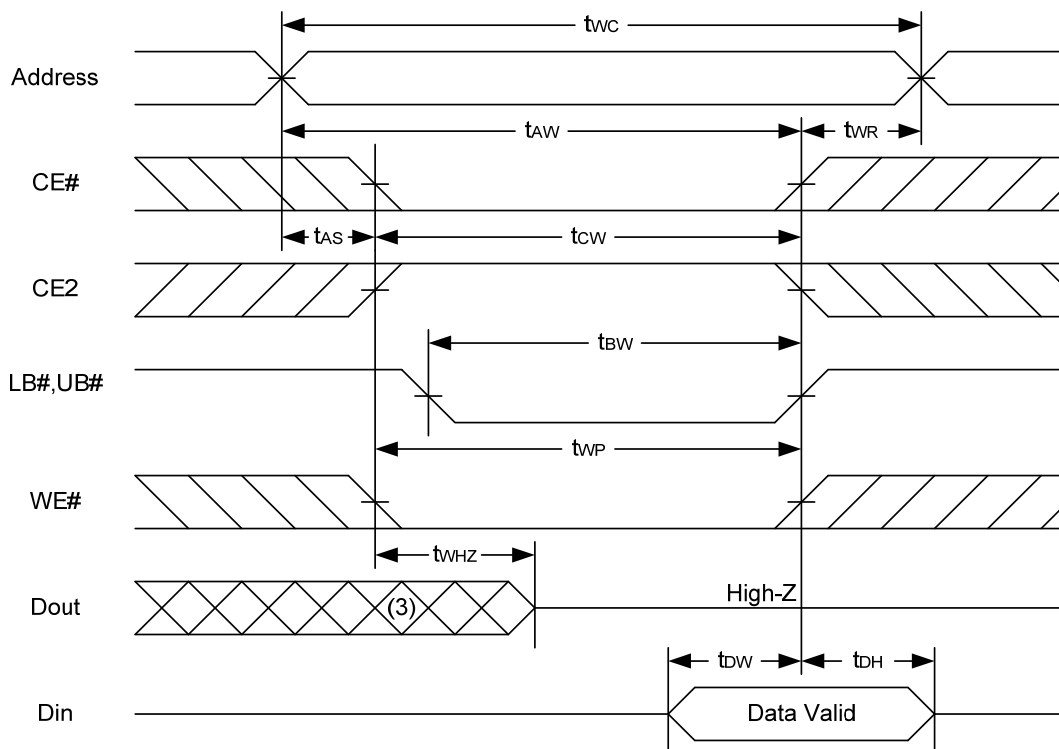

Notes :

1. A write occurs during the overlap of a low CE#, high CE2, low WE#, LB# or UB# = low.
2. During a WE# controlled write cycle with OE# low,  $t_{WP}$  must be greater than  $t_{WHZ} + t_{DW}$  to allow the drivers to turn off and data to be placed on the bus.
3. During this period, I/O pins are in the output state, and input signals must not be applied.
4. If the CE#, LB#, UB# low transition and CE2 high transition occurs simultaneously with or after WE# low transition, the outputs remain in a high impedance state.
5.  $t_{ow}$  and  $t_{whz}$  are specified with  $C_L = 5pF$ . Transition is measured  $\pm 500mV$  from steady state.



### DATA RETENTION CHARACTERISTICS

PARAMETER	SYMBOL	TEST CONDITION	MIN.	TYP.	MAX.	UNIT		
V <sub>CC</sub> for Data Retention	V <sub>DR</sub>	CE# ≥ V <sub>CC</sub> - 0.2V or CE2 ≤ 0.2V	1.2	-	3.6	V		
Data Retention Current	I <sub>DR</sub>	V <sub>CC</sub> = 1.2V CE# ≥ V <sub>CC</sub> - 0.2V or CE2 ≤ 0.2V Other pins at 0.2V or V <sub>CC</sub> - 0.2V	-SL	25°C	-	10	32	μA
			-SLI	40°C	-	10	36	μA
			-SL		-	-	100	μA
			-SLI		-	-	160	μA
Chip Disable to Data Retention Time	t <sub>CDR</sub>	See Data Retention Waveforms (below)	0	-	-	ns		
Recovery Time	t <sub>R</sub>		t <sub>RC</sub> *	-	-	ns		

t<sub>RC</sub>\* = Read Cycle Time

### DATA RETENTION WAVEFORM

Low V<sub>CC</sub> Data Retention Waveform (1) (CE# controlled)

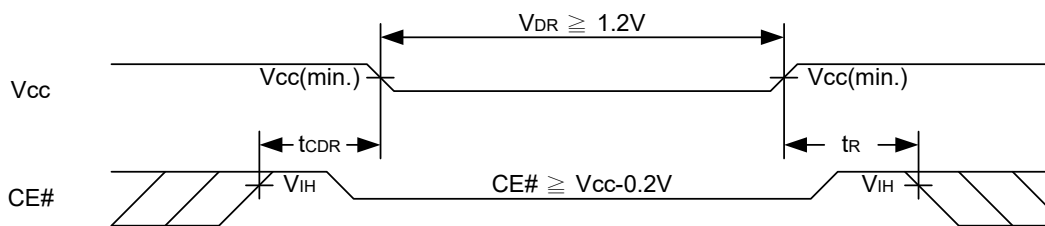

Low V<sub>CC</sub> Data Retention Waveform (2) (CE2 controlled)

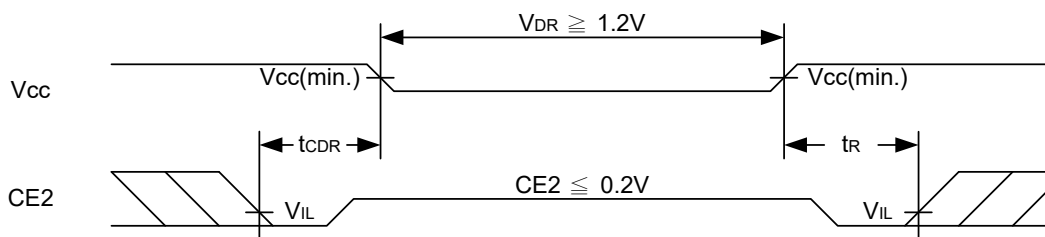

Low V<sub>CC</sub> Data Retention Waveform (3) (LB#, UB# controlled)

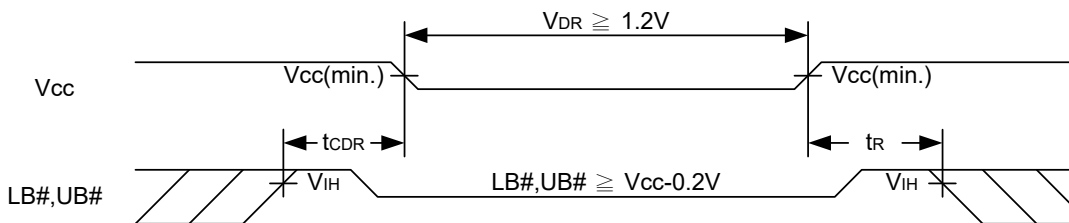

Lyontek Inc. reserves the rights to change the specifications and products without notice.

2F, No.17, Industry E. Rd. II, Science-Based Industrial Park, Hsinchu 300, Taiwan.

TEL: 886-3-6668838

FAX: 886-3-6668836



### PACKAGE OUTLINE DIMENSION

48-pin 12mm x 20mm TSOP I Package Outline Dimension

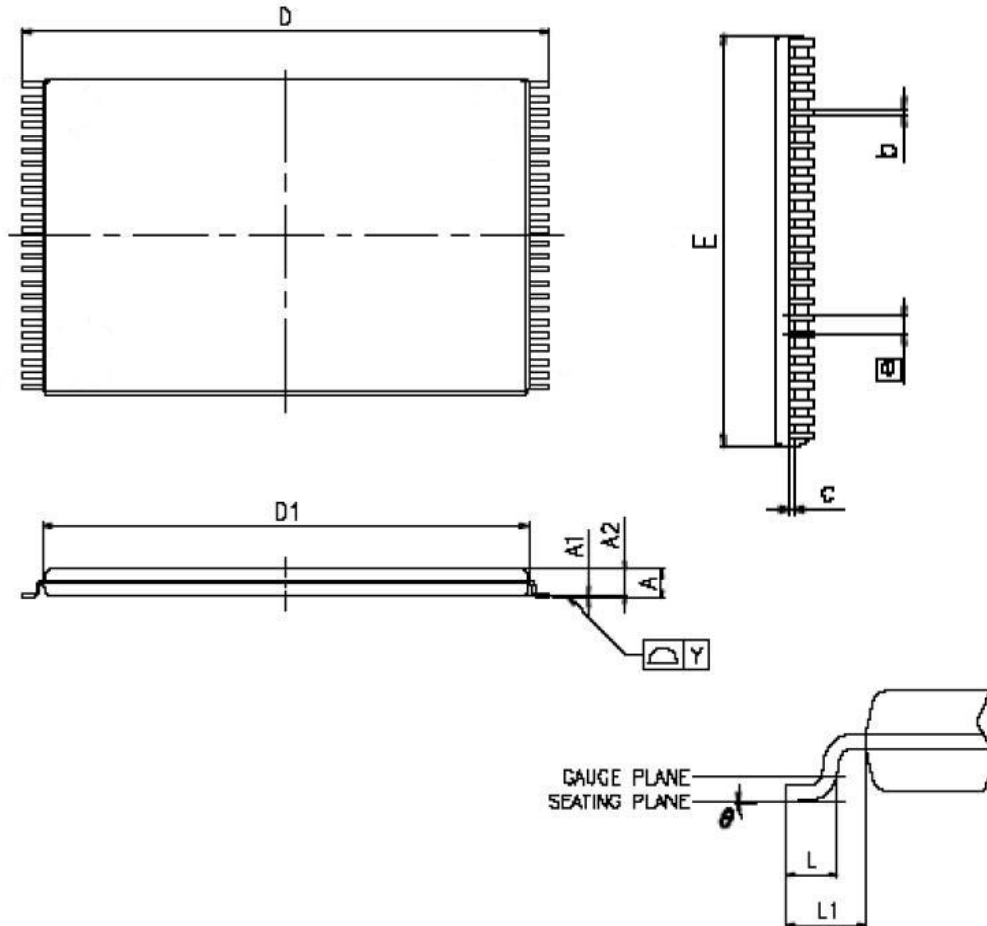

VARIATIONS (ALL DIMENSIONS SHOWN IN MM)

SYMBOLS	MIN.	NOM.	MAX
A	-	-	1.20
A1	0.05	-	0.15
A2	0.95	1.00	1.05
b	0.17	0.22	0.27
c	0.10	-	0.21
$\Delta$ D	19.80	20.00	20.20
$\Delta$ D1	18.30	18.40	18.50
$\Delta$ E	11.90	12.00	12.10
$\square$	0.50 BASIC		
L	0.50	0.60	0.70
$\Delta$ L1	-	0.80	-
$\Delta$ Y	-	-	0.10
$\Delta$ $\theta$	$\theta$	-	5°

NOTES:

1. JEDEC OUTLINE : MO-142 DD
2. PROFILE TOLERANCE ZONES FOR D1 AND E DO NOT INCLUDE MOLD PROTRUSION. ALLOWABLE MOLD PROTRUSION ON E IS 0.15mm PER SIDE AND ON D1 IS 0.25mm PER SIDE.
3. DIMENSION b DOES NOT INCLUDE DAMBAR PROTRUSION. ALLOWABLE DAMBAR PROTRUSION SHALL BE 0.08mm TOTAL IN EXCESS OF THE b DIMENSION AT MAXIMUM MATERIAL CONDITION. DAMBAR CANNOT BE LOCATED ON THE LOWER RADIUS OR THE FOOT.

Lyontek Inc. reserves the rights to change the specifications and products without notice.

2F, No.17, Industry E. Rd. II, Science-Based Industrial Park, Hsinchu 300, Taiwan.

TEL: 886-3-6668838

FAX: 886-3-6668836



### ORDERING INFORMATION

Package Type	Access Time (Speed)(ns)	Power Type	Temperature Range(°C)	Packing Type	Lyontek Item No.
48-pin (12mm x 20mm) TSOP I	55	Special Ultra Low Power	0°C~70°C	Tray	LY62L409816ALL-55SL
				Tape Reel	LY62L409816ALL-55SLT
			-40°C~85°C	Tray	LY62L409816ALL-55SLI
				Tape Reel	LY62L409816ALL-55SLIT



**Lyontek Inc.**

**LY62L409816A**

Rev. 1.4

**64M BITS (4Mx16/8Mx8 Switchable) LOW POWER CMOS SRAM**

---

THIS PAGE IS LEFT BLANK INTENTIONALLY.