



**Lyontek Inc.**

**LY62W12816B**

Rev.1.0

**128K X 16 BIT LOW POWER CMOS SRAM**

---

**REVISION HISTORY**

| <b><u>Revision</u></b> | <b><u>Description</u></b> | <b><u>Issue Date</u></b> |
|------------------------|---------------------------|--------------------------|
| Rev. 1.0               | Initial Issue             | Mar.19.2020              |



### FEATURES

- Fast access time : 45/55/70ns
- Low power consumption:  
Operating current : 15/12/10mA (TYP.)  
Standby current : 1.5μA (TYP.)
- Single 2.7V ~ 5.5V power supply
- All outputs TTL compatible
- Fully static operation
- Tri-state output
- Data byte control : LB# (DQ0 ~ DQ7)  
UB# (DQ8 ~ DQ15)
- Data retention voltage : 1.5V (MIN.)
- **Green package available**
- Package : 44-pin 400 mil TSOP II  
48-ball 6mm x 8mm TFBGA

### GENERAL DESCRIPTION

The LY62W12816B is a 2,097,152-bit low power CMOS static random access memory organized as 131,072 words by 16 bits. It is fabricated using very high performance, high reliability CMOS technology. Its standby current is stable within the range of operating temperature.

The LY62W12816B is well designed for low power application, and particularly well suited for battery back-up nonvolatile memory application.

The LY62W12816B operates from a single power supply of 2.7V ~ 5.5V and all outputs are fully TTL compatible.

### PRODUCT FAMILY

| Product Family | Operating Temperature | Vcc Range  | Speed      | Power Dissipation               |                                  |
|----------------|-----------------------|------------|------------|---------------------------------|----------------------------------|
|                |                       |            |            | Standby(I <sub>SB1</sub> ,TYP.) | Operating(I <sub>CC</sub> ,TYP.) |
| LY62W12816B    | 0 ~ 70°C              | 2.7 ~ 5.5V | 45/55/70ns | 1.5μA                           | 15/12/10mA                       |
| LY62W12816B(I) | -40 ~ 85°C            | 2.7 ~ 5.5V | 45/55/70ns | 1.5μA                           | 15/12/10mA                       |

### FUNCTIONAL BLOCK DIAGRAM

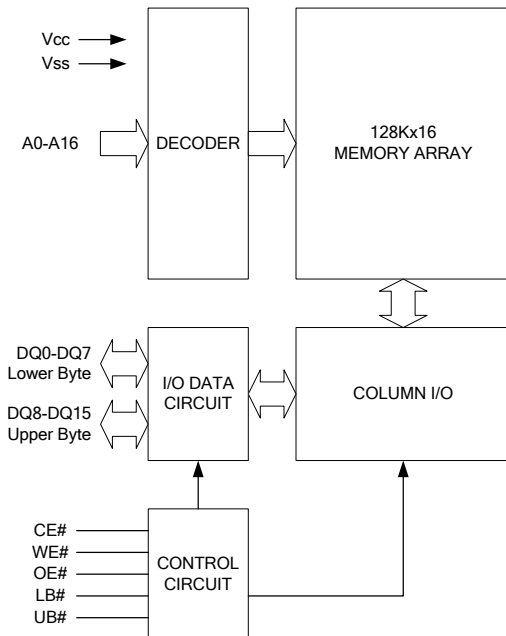

### PIN DESCRIPTION

| SYMBOL     | DESCRIPTION         |
|------------|---------------------|
| A0 - A16   | Address Inputs      |
| DQ0 - DQ15 | Data Inputs/Outputs |
| CE#        | Chip Enable Input   |
| WE#        | Write Enable Input  |
| OE#        | Output Enable Input |
| LB#        | Lower Byte Control  |
| UB#        | Upper Byte Control  |
| Vcc        | Power Supply        |
| Vss        | Ground              |
| NC         | No Connection       |



### PIN CONFIGURATION

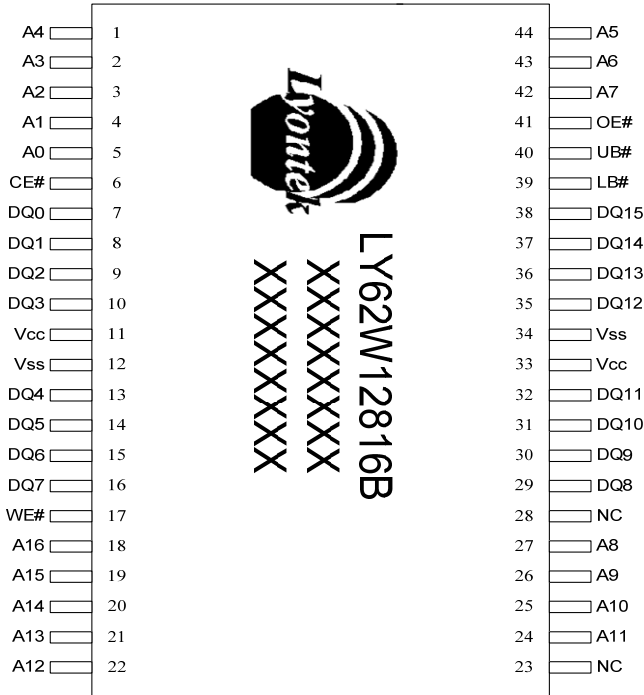

TSOP II

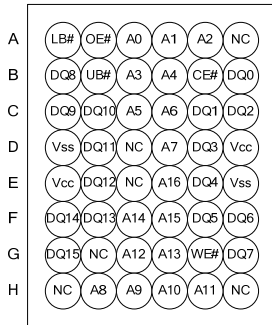

TFBGA(See through with Top View)

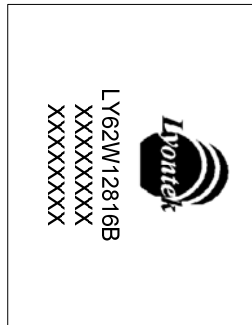

TFBGA(Top View)



#### ABSOLUTE MAXIMUM RATINGS\*

| PARAMETER  | SYMBOL           | RATING                       | UNIT |
|--|------------------|------------------------------|------|
| Voltage on V <sub>CC</sub> relative to V <sub>SS</sub> | V <sub>T1</sub>  | -0.5 to 6.5                  | V    |
| Voltage on any other pin relative to V <sub>SS</sub>   | V <sub>T2</sub>  | -0.5 to V <sub>CC</sub> +0.5 | V    |
| Operating Temperature                                  | T <sub>A</sub>   | 0 to 70(C grade)             | °C   |
|  |                  | -40 to 85(I grade)           |      |
| Storage Temperature                                    | T <sub>STG</sub> | -65 to 150                   | °C   |
| Power Dissipation                                      | P <sub>D</sub>   | 1                            | W    |
| DC Output Current                                      | I <sub>OUT</sub> | 50                           | mA   |

\*Stresses greater than those listed under "Absolute Maximum Ratings" may cause permanent damage to the device. This is a stress rating only and functional operation of the device or any other conditions above those indicated in the operational sections of this specification is not implied. Exposure to the absolute maximum rating conditions for extended period may affect device reliability.

#### TRUTH TABLE

| MODE           | CE# | OE# | WE# | LB# | UB# | I/O OPERATION    |                  | SUPPLY CURRENT                     |
|----------------|-----|-----|-----|-----|-----|------------------|------------------|------------------------------------|
|                |     |     |     |     |     | DQ0 - DQ7        | DQ8 - DQ15       |                                    |
| Standby        | H   | X   | X   | X   | X   | High-Z           | High-Z           | I <sub>SB1</sub>                   |
|                | X   | X   | X   | H   | H   | High-Z           | High-Z           |                                    |
| Output Disable | L   | H   | H   | L   | X   | High-Z           | High-Z           | I <sub>CC</sub> , I <sub>CC1</sub> |
|                | L   | H   | H   | X   | L   | High-Z           | High-Z           |                                    |
| Read           | L   | L   | H   | L   | H   | D <sub>OUT</sub> | High-Z           | I <sub>CC</sub> , I <sub>CC1</sub> |
|                | L   | L   | H   | H   | L   | High-Z           | D <sub>OUT</sub> |                                    |
|                | L   | L   | H   | L   | L   | D <sub>OUT</sub> | D <sub>OUT</sub> |                                    |
| Write          | L   | X   | L   | L   | H   | D <sub>IN</sub>  | High-Z           | I <sub>CC</sub> , I <sub>CC1</sub> |
|                | L   | X   | L   | H   | L   | High-Z           | D <sub>IN</sub>  |                                    |
|                | L   | X   | L   | L   | L   | D <sub>IN</sub>  | D <sub>IN</sub>  |                                    |

Note: H = V<sub>IH</sub>, L = V<sub>IL</sub>, X = Don't care.



### DC ELECTRICAL CHARACTERISTICS

| PARAMETER                              | SYMBOL                        | TEST CONDITION   | MIN.                   | TYP. <sup>*4</sup> | MAX.                 | UNIT |    |
|--|-------------------------------|--|------------------------|--------------------|----------------------|------|----|
| Supply Voltage                         | V <sub>CC</sub>               |  | 2.7                    | 3.0                | 5.5                  | V    |    |
| Input High Voltage                     | V <sub>IH</sub> <sup>*1</sup> |  | 0.7*V <sub>CC</sub>    | -                  | V <sub>CC</sub> +0.3 | V    |    |
| Input Low Voltage                      | V <sub>IL</sub> <sup>*2</sup> |  | -0.2                   | -                  | 0.6                  | V    |    |
| Input Leakage Current                  | I <sub>LI</sub>               | V <sub>CC</sub> ≥ V <sub>IN</sub> ≥ V <sub>SS</sub>  | -1                     | -                  | 1                    | μA   |    |
| Output Leakage Current                 | I <sub>LO</sub>               | V <sub>CC</sub> ≥ V <sub>OUT</sub> ≥ V <sub>SS</sub> ,<br>Output Disabled                              | -1                     | -                  | 1                    | μA   |    |
| Output High Voltage                    | V <sub>OH</sub>               | I <sub>OH</sub> = -1mA   | 2.4                    | 2.7                | -                    | V    |    |
| Output Low Voltage                     | V <sub>OL</sub>               | I <sub>OL</sub> = 2mA  | -                      | -                  | 0.4                  | V    |    |
| Average Operating Power supply Current | I <sub>CC</sub>               | Cycle time = Min.<br>CE# ≤ 0.2V, I <sub>I/O</sub> = 0mA<br>Other pins at 0.2V or V <sub>CC</sub> -0.2V | -45                    | -                  | 15                   | 25   | mA |
|  |                               |  | -55                    | -                  | 12                   | 20   | mA |
|  |                               |  | -70                    | -                  | 10                   | 18   | mA |
|  | I <sub>CC1</sub>              | Cycle time = 1μs<br>CE# ≤ 0.2V, I <sub>I/O</sub> = 0mA<br>Other pins at 0.2V or V <sub>CC</sub> -0.2V  | -                      | 2                  | 4                    | mA   |    |
| Standby Power Supply Current           | I <sub>SB1</sub>              | CE# ≥ V <sub>CC</sub> -0.2V<br>Other pins at 0.2V or V <sub>CC</sub> -0.2V                             | SL <sup>*5</sup> 25°C  | -                  | 1.2                  | 3.2  | μA |
|  |                               |  | SLI <sup>*5</sup> 40°C | -                  | 1.5                  | 3.5  | μA |
|  |                               |  | SL                     | -                  | 1.5                  | 10   | μA |
|  |                               |  | SLI                    | -                  | 1.5                  | 15   | μA |

Notes:

- V<sub>IH</sub>(max) = V<sub>CC</sub> + 3.0V for pulse width less than 10ns.
- V<sub>IL</sub>(min) = V<sub>SS</sub> - 3.0V for pulse width less than 10ns.
- Over/Undershoot specifications are characterized, not 100% tested.
- Typical values are included for reference only and are not guaranteed or tested.  
Typical values are measured at V<sub>CC</sub> = V<sub>CC</sub>(TYP.) and T<sub>A</sub> = 25°C
- This parameter is measured at V<sub>CC</sub> = 3.0V

### CAPACITANCE (T<sub>A</sub> = 25°C, f = 1.0MHz)

| PARAMETER                | SYMBOL           | MIN. | MAX. | UNIT |
|--------------------------|------------------|------|------|------|
| Input Capacitance        | C <sub>IN</sub>  | -    | 6    | pF   |
| Input/Output Capacitance | C <sub>I/O</sub> | -    | 8    | pF   |

Note : These parameters are guaranteed by device characterization, but not production tested.

### AC TEST CONDITIONS

|  |   |
|--|---|
| Input Pulse Levels                       | 0.2V to V <sub>CC</sub> - 0.2V  |
| Input Rise and Fall Times                | 3ns   |
| Input and Output Timing Reference Levels | 1.5V  |
| Output Load                              | C <sub>L</sub> = 30pF + 1TTL, I <sub>OH</sub> /I <sub>OL</sub> = -2mA/4mA |



### AC ELECTRICAL CHARACTERISTICS

#### (1) READ CYCLE

| PARAMETER                          | SYM.               | LY62W12816B-45 |      | LY62W12816B-55 |      | LY62W12816B-70 |      | UNIT |
|------------------------------------|--------------------|----------------|------|----------------|------|----------------|------|------|
|                                    |                    | MIN.           | MAX. | MIN.           | MAX. | MIN.           | MAX. |      |
| Read Cycle Time                    | t <sub>RC</sub>    | 45             | -    | 55             | -    | 70             | -    | ns   |
| Address Access Time                | t <sub>AA</sub>    | -              | 45   | -              | 55   | -              | 70   | ns   |
| Chip Enable Access Time            | t <sub>ACE</sub>   | -              | 45   | -              | 55   | -              | 70   | ns   |
| Output Enable Access Time          | t <sub>OE</sub>    | -              | 25   | -              | 30   | -              | 35   | ns   |
| Chip Enable to Output in Low-Z     | t <sub>CLZ</sub> * | 10             | -    | 10             | -    | 10             | -    | ns   |
| Output Enable to Output in Low-Z   | t <sub>OLZ</sub> * | 5              | -    | 5              | -    | 5              | -    | ns   |
| Chip Disable to Output in High-Z   | t <sub>CHZ</sub> * | -              | 20   | -              | 20   | -              | 25   | ns   |
| Output Disable to Output in High-Z | t <sub>OHZ</sub> * | -              | 20   | -              | 20   | -              | 25   | ns   |
| Output Hold from Address Change    | t <sub>OH</sub>    | 10             | -    | 10             | -    | 10             | -    | ns   |
| LB#, UB# Access Time               | t <sub>BA</sub>    | -              | 45   | -              | 55   | -              | 70   | ns   |
| LB#, UB# to High-Z Output          | t <sub>BHZ</sub> * | -              | 20   | -              | 25   | -              | 30   | ns   |
| LB#, UB# to Low-Z Output           | t <sub>BLZ</sub> * | 10             | -    | 10             | -    | 10             | -    | ns   |

#### (2) WRITE CYCLE

| PARAMETER                        | SYM.               | LY62W12816B-45 |      | LY62W12816B-55 |      | LY62W12816B-70 |      | UNIT |
|----------------------------------|--------------------|----------------|------|----------------|------|----------------|------|------|
|                                  |                    | MIN.           | MAX. | MIN.           | MAX. | MIN.           | MAX. |      |
| Write Cycle Time                 | t <sub>WC</sub>    | 45             | -    | 55             | -    | 70             | -    | ns   |
| Address Valid to End of Write    | t <sub>AW</sub>    | 40             | -    | 50             | -    | 60             | -    | ns   |
| Chip Enable to End of Write      | t <sub>CW</sub>    | 40             | -    | 50             | -    | 60             | -    | ns   |
| Address Set-up Time              | t <sub>AS</sub>    | 0              | -    | 0              | -    | 0              | -    | ns   |
| Write Pulse Width                | t <sub>WP</sub>    | 35             | -    | 45             | -    | 55             | -    | ns   |
| Write Recovery Time              | t <sub>WR</sub>    | 0              | -    | 0              | -    | 0              | -    | ns   |
| Data to Write Time Overlap       | t <sub>DW</sub>    | 20             | -    | 25             | -    | 30             | -    | ns   |
| Data Hold from End of Write Time | t <sub>DH</sub>    | 0              | -    | 0              | -    | 0              | -    | ns   |
| Output Active from End of Write  | t <sub>OW</sub> *  | 5              | -    | 5              | -    | 5              | -    | ns   |
| Write to Output in High-Z        | t <sub>WHZ</sub> * | -              | 20   | -              | 20   | -              | 25   | ns   |
| LB#, UB# Valid to End of Write   | t <sub>BW</sub>    | 40             | -    | 50             | -    | 60             | -    | ns   |

\*These parameters are guaranteed by device characterization, but not production tested.



### TIMING WAVEFORMS

#### READ CYCLE 1 (Address Controlled) (1,2)

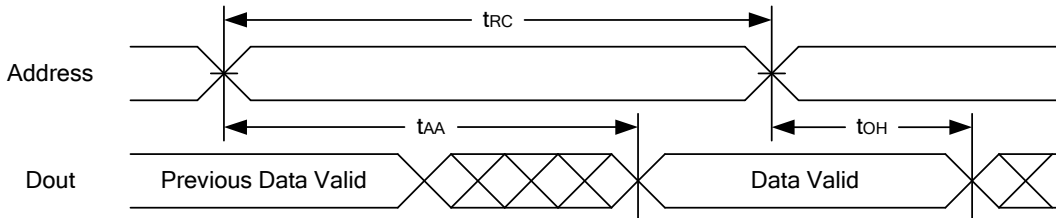

#### READ CYCLE 2 (CE# and OE# Controlled) (1,3,4,5)

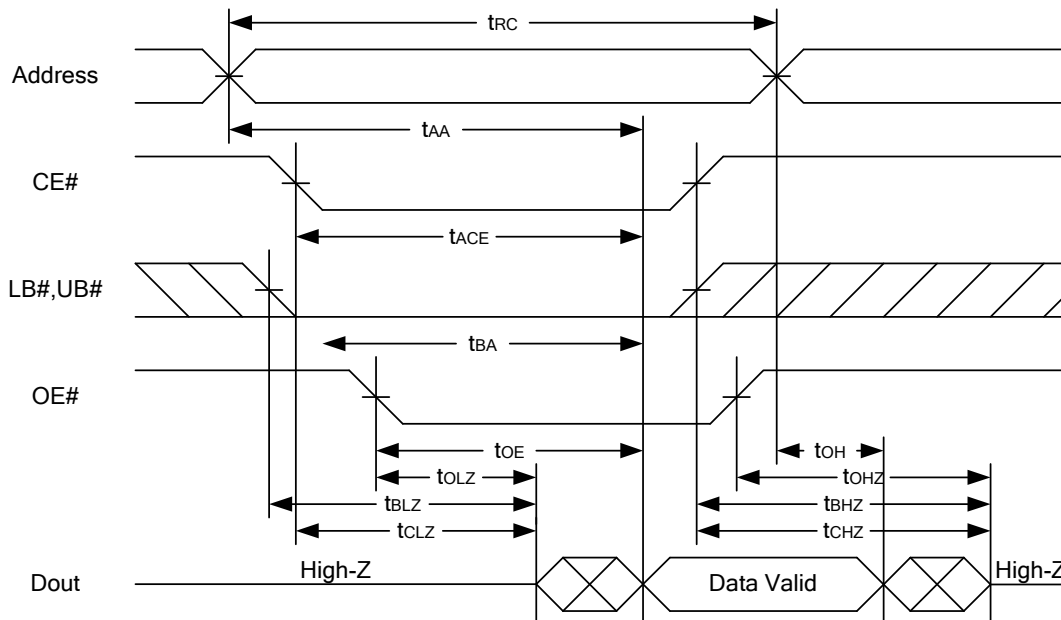

Notes :

1. WE# is high for read cycle.
2. Device is continuously selected OE# = low, CE# = low, LB# or UB# = low.
3. Address must be valid prior to or coincident with CE# = low, LB# or UB# = low transition; otherwise  $t_{AA}$  is the limiting parameter.
4.  $t_{CLZ}$ ,  $t_{BLZ}$ ,  $t_{OLZ}$ ,  $t_{CHZ}$ ,  $t_{BHZ}$  and  $t_{OHZ}$  are specified with  $C_L = 5pF$ . Transition is measured  $\pm 500mV$  from steady state.
5. At any given temperature and voltage condition,  $t_{CHZ}$  is less than  $t_{CLZ}$ ,  $t_{BHZ}$  is less than  $t_{BLZ}$ ,  $t_{OHZ}$  is less than  $t_{OLZ}$ .



#### WRITE CYCLE 1 (WE# Controlled) (1,2,4,5)

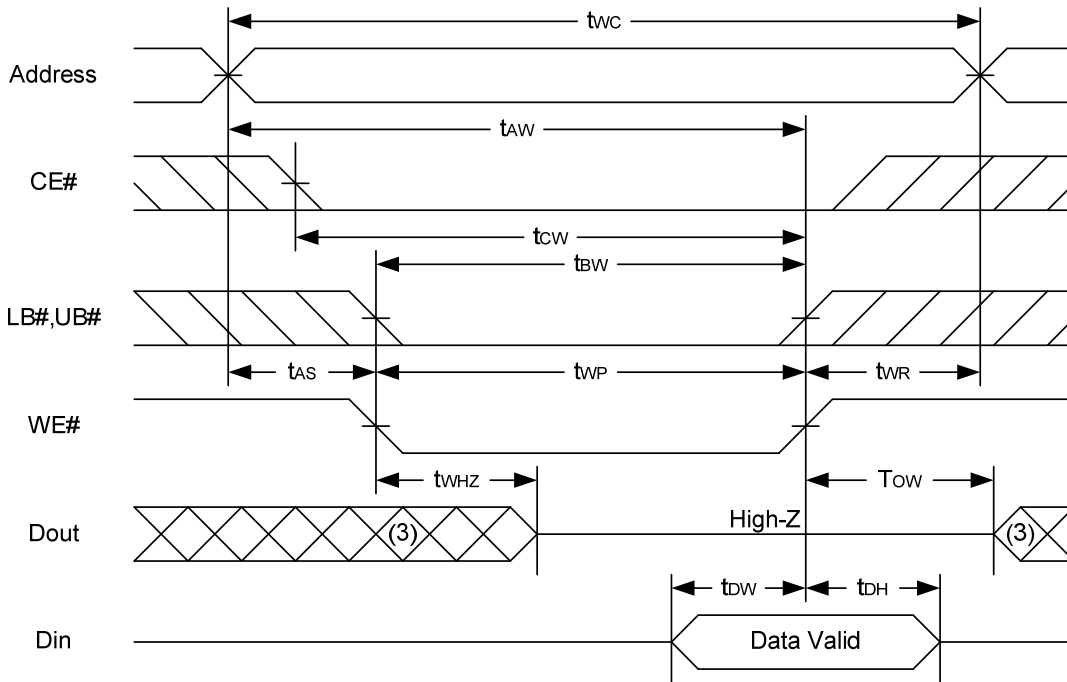

#### WRITE CYCLE 2 (CE# Controlled) (1,4,5)

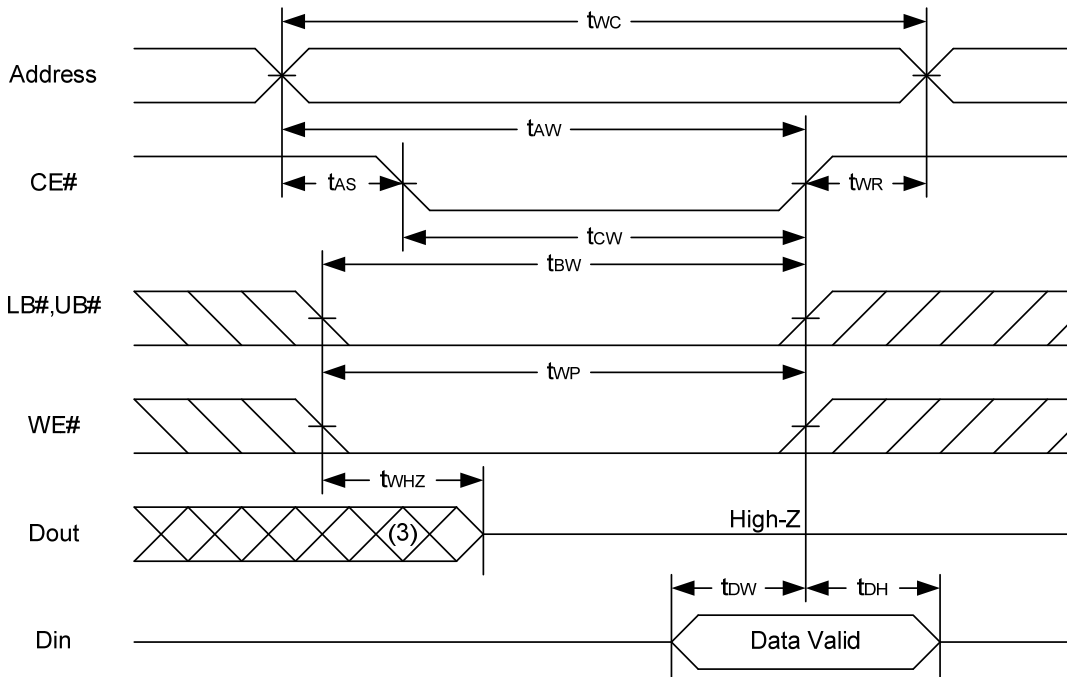





#### WRITE CYCLE 3 (LB#,UB# Controlled) (1,4,5)

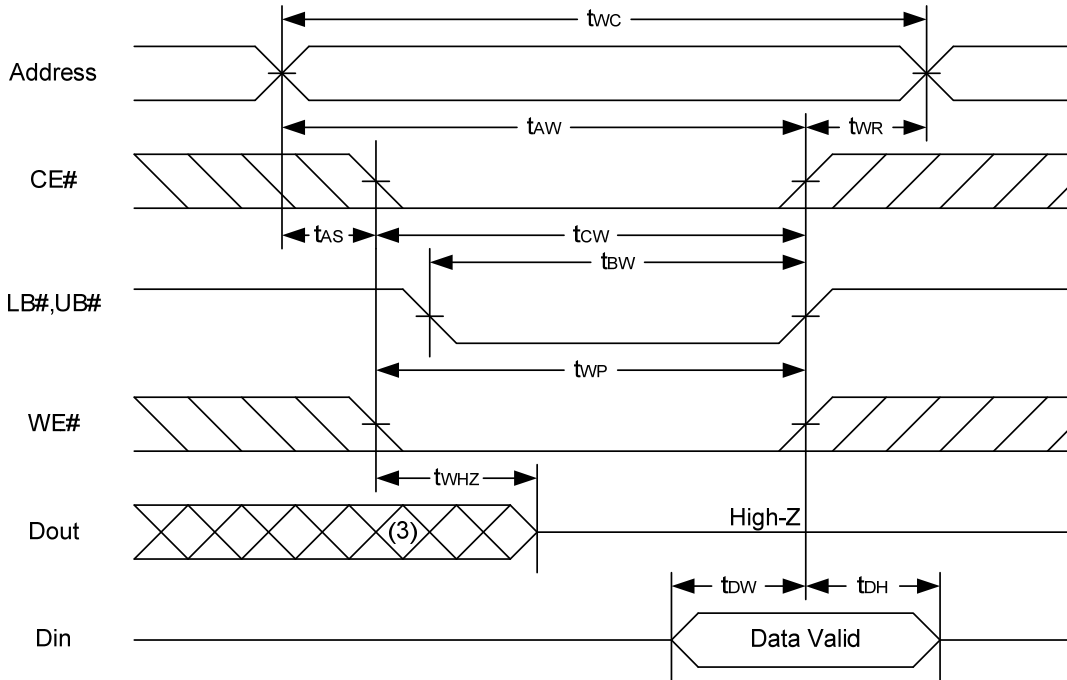

Notes :

1. A write occurs during the overlap of a low CE#, low WE#, LB# or UB# = low.
2. During a WE# controlled write cycle with OE# low,  $t_{WP}$  must be greater than  $t_{WHZ} + t_{DW}$  to allow the drivers to turn off and data to be placed on the bus.
3. During this period, I/O pins are in the output state, and input signals must not be applied.
4. If the CE#, LB#, UB# low transition occurs simultaneously with or after WE# low transition, the outputs remain in a high impedance state.
5.  $t_{OW}$  and  $t_{WHZ}$  are specified with  $C_L = 5pF$ . Transition is measured  $\pm 500mV$  from steady state.



**DATA RETENTION CHARACTERISTICS**

| PARAMETER                           | SYMBOL           | TEST CONDITION   | MIN.              | TYP. | MAX. | UNIT |     |    |
|-------------------------------------|------------------|--|-------------------|------|------|------|-----|----|
| V <sub>CC</sub> for Data Retention  | V <sub>DR</sub>  | CE# ≥ V <sub>CC</sub> -0.2V  | 1.5               | -    | 5.5  | V    |     |    |
| Data Retention Current              | I <sub>DR</sub>  | V <sub>CC</sub> = 1.5V<br>CE# ≥ V <sub>CC</sub> -0.2V<br>Other pins at 0.2V or V <sub>CC</sub> -0.2V | SL                | 25°C | -    | 1.2  | 3.2 | μA |
|                                     |                  |  | SLI               | 40°C | -    | 1.5  | 3.5 | μA |
|                                     |                  |  | SL                |      | -    | 1.5  | 10  | μA |
|                                     |                  |  | SLI               |      | -    | 1.5  | 15  | μA |
| Chip Disable to Data Retention Time | t <sub>CDR</sub> | See Data Retention Waveforms (below)   | 0                 | -    | -    | ns   |     |    |
| Recovery Time                       | t <sub>R</sub>   |  | t <sub>RC</sub> * | -    | -    | ns   |     |    |

t<sub>RC</sub>\* = Read Cycle Time

**DATA RETENTION WAVEFORM**

**Low V<sub>CC</sub> Data Retention Waveform (1) (CE# controlled)**

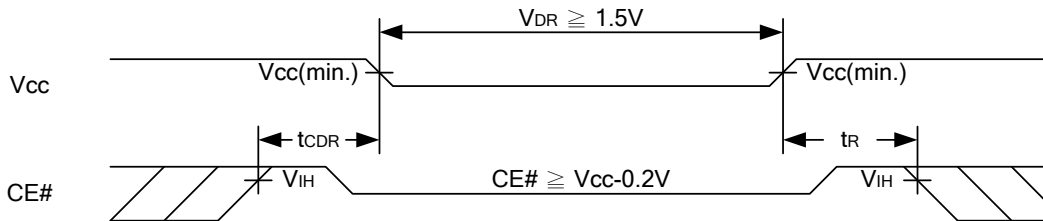

**Low V<sub>CC</sub> Data Retention Waveform (2) (LB#, UB# controlled)**

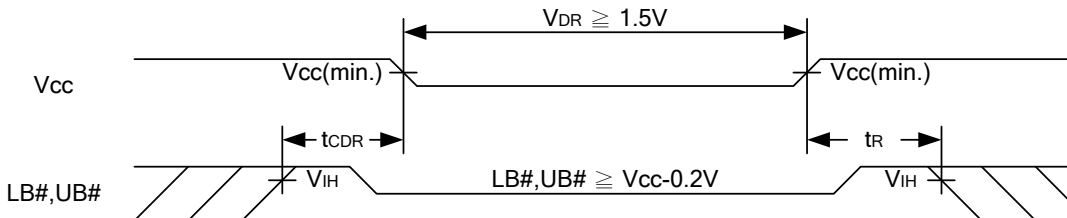



**PACKAGE OUTLINE DIMENSION**

**44-pin 400 mil TSOP II Package Outline Dimension**

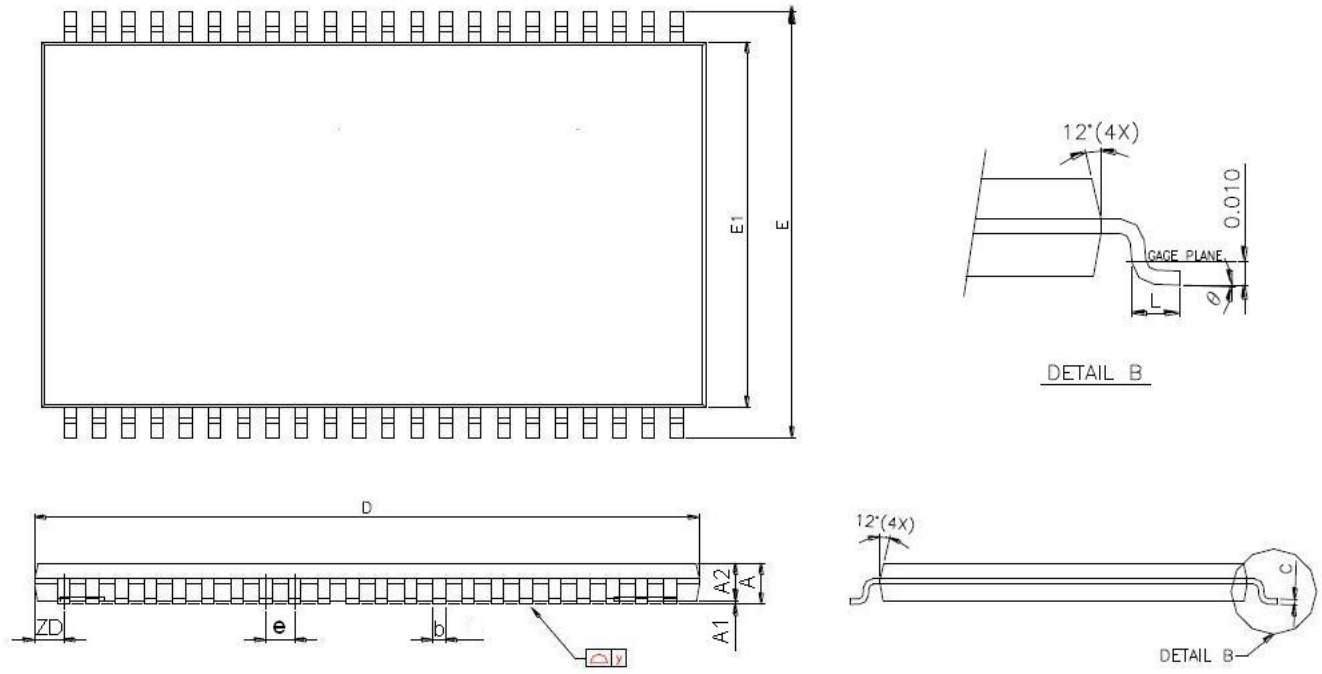

| SYMBOLS | DIMENSIONS IN MILLMETERS |        |        | DIMENSIONS IN MILS |      |      |
|---------|--------------------------|--------|--------|--------------------|------|------|
|         | MIN.                     | NOM.   | MAX.   | MIN.               | NOM. | MAX. |
| A       | -                        | -      | 1.20   | -                  | -    | 47.2 |
| A1      | 0.05                     | 0.10   | 0.15   | 2.0                | 3.9  | 5.9  |
| A2      | 0.95                     | 1.00   | 1.05   | 37.4               | 39.4 | 41.3 |
| b       | 0.30                     | -      | 0.45   | 11.8               | -    | 17.7 |
| c       | 0.12                     | -      | 0.21   | 4.7                | -    | 8.3  |
| D       | 18.212                   | 18.415 | 18.618 | 717                | 725  | 733  |
| E       | 11.506                   | 11.760 | 12.014 | 453                | 463  | 473  |
| E1      | 9.957                    | 10.160 | 10.363 | 392                | 400  | 408  |
| e       | -                        | 0.800  | -      | -                  | 31.5 | -    |
| L       | 0.40                     | 0.50   | 0.60   | 15.7               | 19.7 | 23.6 |
| ZD      | -                        | 0.805  | -      | -                  | 31.7 | -    |
| y       | -                        | -      | 0.076  | -                  | -    | 3    |
| θ       | 0°                       | 3°     | 6°     | 0°                 | 3°   | 6°   |



**48-ball 6mm × 8mm TFBGA Package Outline Dimension**

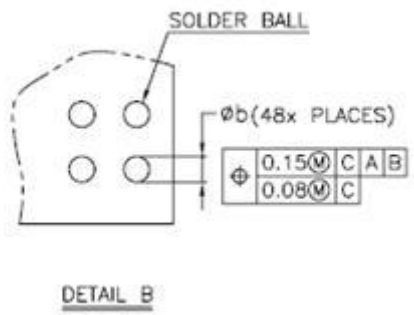
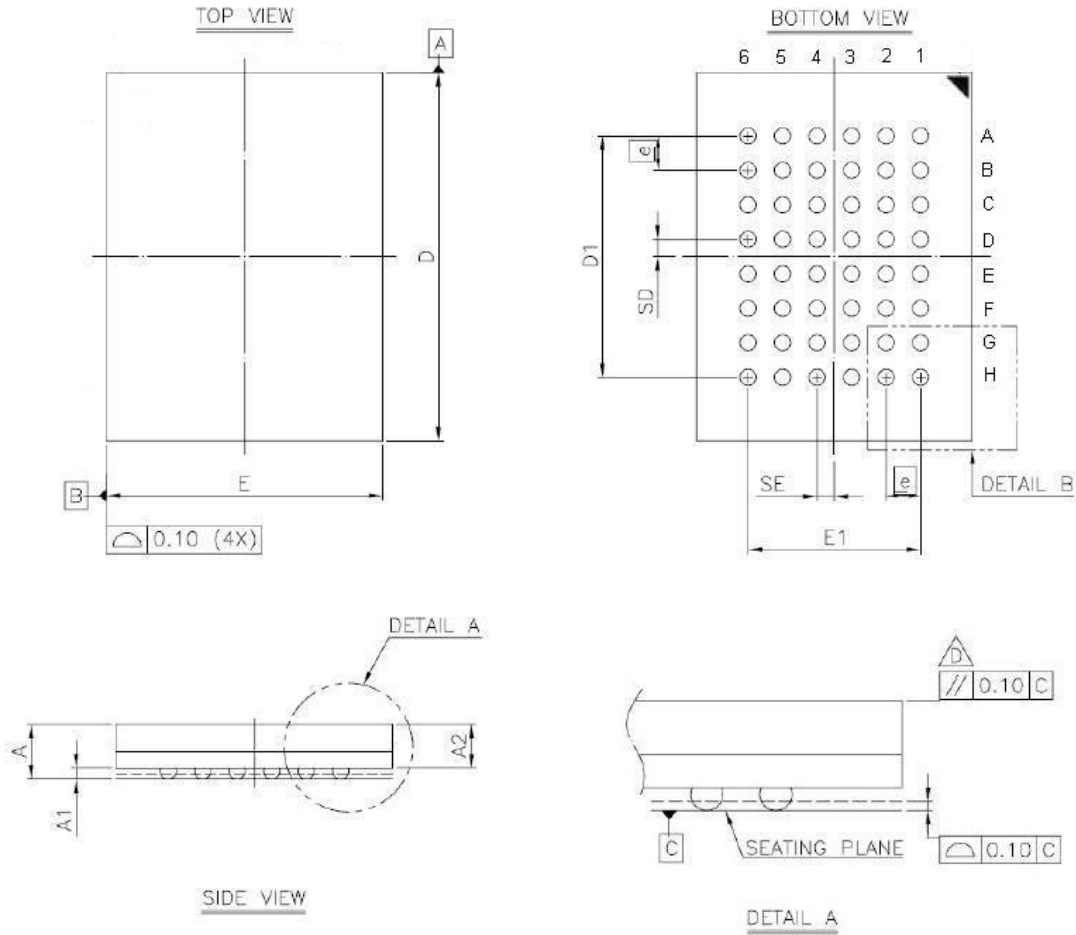

| SYM. | DIMENSION (mm) |      |      | DIMENSION (inch) |       |       |
|------|----------------|------|------|------------------|-------|-------|
|      | MIN.           | NOM. | MAX. | MIN.             | NOM.  | MAX.  |
| A    | —              | —    | 1.20 | —                | —     | 0.047 |
| A1   | 0.20           | 0.25 | 0.30 | 0.008            | 0.010 | 0.012 |
| A2   | —              | —    | 0.94 | —                | —     | 0.037 |
| b    | 0.30           | 0.35 | 0.40 | 0.012            | 0.014 | 0.016 |
| D    | 7.95           | 8.00 | 8.05 | 0.313            | 0.315 | 0.317 |
| D1   | 5.25 BSC       |      |      | 0.207 BSC        |       |       |
| E    | 5.95           | 6.00 | 6.05 | 0.234            | 0.236 | 0.238 |
| E1   | 3.75 BSC       |      |      | 0.148 BSC        |       |       |
| SE   | 0.375 TYP      |      |      | 0.015 TYP        |       |       |
| SD   | 0.375 TYP      |      |      | 0.015 TYP        |       |       |
| e    | 0.75 BSC       |      |      | 0.030 BSC        |       |       |

NOTE:  
 1. CONTROLLING DIMENSION : MILLIMETER.  
 2. REFERENCE DOCUMENT : JEDEC MO-207.



#### ORDERING INFORMATION

| Package Type              | Access Time (Speed)(ns) | Power Type              | Temperature Range(°C) | Packing Type | Lyontek Item No.     |
|---------------------------|-------------------------|-------------------------|-----------------------|--------------|----------------------|
| 44-pin(400mil)<br>TSOP II | 45                      | Special Ultra Low Power | 0°C~70°C              | Tray         | LY62W12816BML-45SL   |
|                           |                         |                         |                       | Tape Reel    | LY62W12816BML-45SLT  |
|                           |                         |                         | -40°C~85°C            | Tray         | LY62W12816BML-45SLI  |
|                           |                         |                         |                       | Tape Reel    | LY62W12816BML-45SLIT |
|                           | 55                      | Special Ultra Low Power | 0°C~70°C              | Tray         | LY62W12816BML-55SL   |
|                           |                         |                         |                       | Tape Reel    | LY62W12816BML-55SLT  |
|                           |                         |                         | -40°C~85°C            | Tray         | LY62W12816BML-55SLI  |
|                           |                         |                         |                       | Tape Reel    | LY62W12816BML-55SLIT |
|                           | 70                      | Special Ultra Low Power | 0°C~70°C              | Tray         | LY62W12816BML-70SL   |
|                           |                         |                         |                       | Tape Reel    | LY62W12816BML-70SLT  |
|                           |                         |                         | -40°C~85°C            | Tray         | LY62W12816BML-70SLI  |
|                           |                         |                         |                       | Tape Reel    | LY62W12816BML-70SLIT |



#### ORDERING INFORMATION

| Package Type                    | Access Time (Speed)(ns) | Power Type                 | Temperature Range(°C) | Packing Type | Lyontek Item No.     |
|---------------------------------|-------------------------|----------------------------|-----------------------|--------------|----------------------|
| 48-ball<br>(6mm x 8mm)<br>TFBGA | 45                      | Special<br>Ultra Low Power | 0°C~70°C              | Tray         | LY62W12816BGL-45SL   |
|                                 |                         |                            |                       | Tape Reel    | LY62W12816BGL-45SLT  |
|                                 |                         |                            | -40°C~85°C            | Tray         | LY62W12816BGL-45SLI  |
|                                 |                         |                            |                       | Tape Reel    | LY62W12816BGL-45SLIT |
|                                 | 55                      | Special<br>Ultra Low Power | 0°C~70°C              | Tray         | LY62W12816BGL-55SL   |
|                                 |                         |                            |                       | Tape Reel    | LY62W12816BGL-55SLT  |
|                                 |                         |                            | -40°C~85°C            | Tray         | LY62W12816BGL-55SLI  |
|                                 |                         |                            |                       | Tape Reel    | LY62W12816BGL-55SLIT |
|                                 | 70                      | Special<br>Ultra Low Power | 0°C~70°C              | Tray         | LY62W12816BGL-70SL   |
|                                 |                         |                            |                       | Tape Reel    | LY62W12816BGL-70SLT  |
|                                 |                         |                            | -40°C~85°C            | Tray         | LY62W12816BGL-70SLI  |
|                                 |                         |                            |                       | Tape Reel    | LY62W12816BGL-70SLIT |



**Lyontek Inc.**

**LY62W12816B**

Rev.1.0

**128K X 16 BIT LOW POWER CMOS SRAM**

---

THIS PAGE IS LEFT BLANK INTENTIONALLY.