



REVISION HISTORY

<u>Revision</u>	<u>Description</u>	<u>Issue Date</u>
Rev. 0.1	Initial Issue	Apr.25.2011
Rev. 0.2	Revised TEST CONDITION of V_{IH} in page 3	May.13.2011
Rev. 1.0	Revised Notes item 1 and 2 in page 3 1. $V_{IH(max)} = V_{CC} + 2.0V$ for pulse width less than 6ns. 2. $V_{IL(min)} = V_{SS} - 2.0V$ for pulse width less than 6ns.	Aug.29.2013
	Revised <u>ORDERING INFORMATION</u>	
Rev. 1.1	Deleted WRITE CYCLE Notes : 1.WE#,CE#, LB#, UB# must be high or CE2 must be low during all address transitions. In page 7	Jun.29.2016
Rev. 2.0	1. Deleted FEATURES Standby current : $3\mu A$ (TYP.) SL-version--Page 1 2. Deleted PRODUCT FAMILY Standby(ISB1,TYP.) : $3\mu A$ (SL)--- Page 1 3. Deleted <u>DC ELECTRICAL CHARACTERISTICS</u> : Standby Power Supply Current : ISB1--- Page3 4. Deleted <u>DC ELECTRICAL CHARACTERISTICS</u> : Notes: 5--- Page 3 5. Deleted <u>DATA RETENTION CHARACTERISTICS</u> : Data Retention Current: IDR --- Page 8 6. Revised <u>ORDERING INFORMATION</u> in Page 11~Page14	Jun.18.2024

FEATURES

- Fast access time : 55/70ns
- Low power consumption:
Operating current : 30/20mA (TYP.)
Standby current : 6 μ A (TYP.) LL-version
- Single 2.7V ~ 5.5V power supply
- All inputs and outputs TTL compatible
- Fully static operation
- Tri-state output
- Data byte control : LB# (DQ0 ~ DQ7)
UB# (DQ8 ~ DQ15)
- Data retention voltage : 1.5V (MIN.)
- **Green package available**
- Package : 48-pin 12mm x 20mm TSOP-I
48-ball 6mm x 8mm TFBGA

PRODUCT FAMILY

Product Family	Operating Temperature	Vcc Range	Speed	Power Dissipation	
				Standby(I _{SB1} , TYP.)	Operating(I _{CC} , TYP.)
LY62W51316	0 ~ 70°C	2.7 ~ 5.5V	55/70ns	6 μ A(LL)	30/20mA
LY62W51316(I)	-40 ~ 85°C	2.7 ~ 5.5V	55/70ns	6 μ A(LL)	30/20mA

GENERAL DESCRIPTION

The LY62W51316 is a 8,388,608-bit low power CMOS static random access memory organized as 524,288 words by 16 bits. It is fabricated using very high performance, high reliability CMOS technology. Its standby current is stable within the range of operating temperature.

The LY62W51316 is well designed for low power application, and particularly well suited for battery back-up nonvolatile memory application.

The LY62W51316 operates from a single power supply of 2.7V ~ 5.5V and all inputs and outputs are fully TTL compatible

FUNCTIONAL BLOCK DIAGRAM

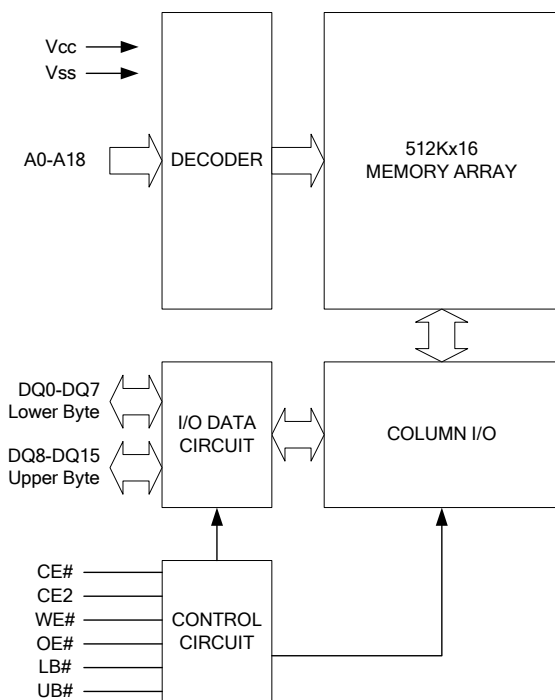

PIN DESCRIPTION

SYMBOL	DESCRIPTION
A0 - A18	Address Inputs
DQ0 - DQ15	Data Inputs/Outputs
CE#, CE2	Chip Enable Input
WE#	Write Enable Input
OE#	Output Enable Input
LB#	Lower Byte Control
UB#	Upper Byte Control
Vcc	Power Supply
Vss	Ground

PIN CONFIGURATION



TSOP-I

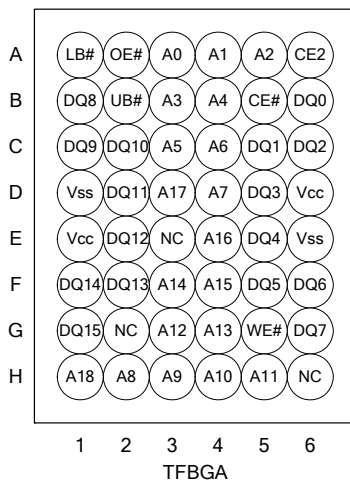

TFBGA

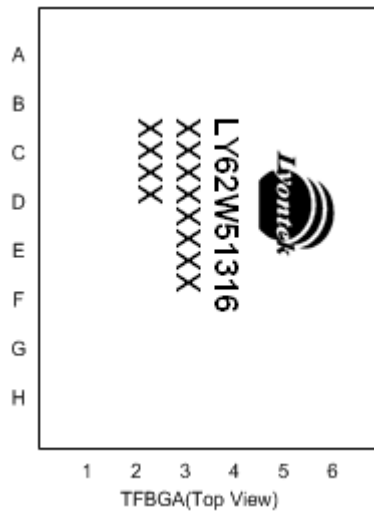

TFBGA(Top View)

ABSOLUTE MAXIMUM RATINGS*

PARAMETER	SYMBOL	RATING	UNIT
Voltage on Vcc relative to Vss	V _{T1}	-0.5 to 6.5	V
Voltage on any other pin relative to Vss	V _{T2}	-0.5 to Vcc+0.5	V
Operating Temperature	T _A	0 to 70(C grade)	°C
		-40 to 85(I grade)	
Storage Temperature	T _{STG}	-65 to 150	°C
Power Dissipation	P _D	1	W
DC Output Current	I _{OUT}	50	mA

*Stresses greater than those listed under "Absolute Maximum Ratings" may cause permanent damage to the device. This is a stress rating only and functional operation of the device or any other conditions above those indicated in the operational sections of this specification is not implied. Exposure to the absolute maximum rating conditions for extended period may affect device reliability.



TRUTH TABLE

MODE	CE#	CE2	OE#	WE#	LB#	UB#	I/O OPERATION		SUPPLY CURRENT
							DQ0-DQ7	DQ8-DQ15	
Standby	H	X	X	X	X	X	High - Z	High - Z	I _{SB} , I _{SB1}
	X	L	X	X	X	X	High - Z	High - Z	
	X	X	X	X	H	H	High - Z	High - Z	
Output Disable	L	H	H	H	L	X	High - Z	High - Z	I _{CC} , I _{CC1}
	L	H	H	H	X	L	High - Z	High - Z	
Read	L	H	L	H	L	H	D _{OUT}	High - Z	I _{CC} , I _{CC1}
	L	H	L	H	H	L	High - Z	D _{OUT}	
	L	H	L	H	L	L	D _{OUT}	D _{OUT}	
Write	L	H	X	L	L	H	D _{IN}	High - Z	I _{CC} , I _{CC1}
	L	H	X	L	H	L	High - Z	D _{IN}	
	L	H	X	L	L	L	D _{IN}	D _{IN}	

Note: H = V_{IH}, L = V_{IL}, X = Don't care.

DC ELECTRICAL CHARACTERISTICS

PARAMETER	SYMBOL	TEST CONDITION	MIN.	TYP.* ⁴	MAX.	UNIT	
Supply Voltage	V _{CC}		2.7	3.0	5.5	V	
Input High Voltage	V _{IH} ¹	V _{CC} = 2.7 ~ 3.6V	2.2	-	V _{CC} +0.5	V	
		V _{CC} = 4.5 ~ 5.5V	2.4	-	V _{CC} +0.5	V	
Input Low Voltage	V _{IL} ²		- 0.2	-	0.6	V	
Input Leakage Current	I _{LI}	V _{CC} ≥ V _{IN} ≥ V _{SS}	- 1	-	1	μA	
Output Leakage Current	I _{LO}	V _{CC} ≥ V _{OUT} ≥ V _{SS} , Output Disabled	- 1	-	1	μA	
Output High Voltage	V _{OH}	I _{OH} = -1mA	2.4	2.7	-	V	
Output Low Voltage	V _{OL}	I _{OL} = 2mA	-	-	0.4	V	
Average Operating Power supply Current	I _{CC}	Cycle time = Min. CE# = V _{IL} and CE2 = V _{IH} I _{I/O} = 0mA Other pins at V _{IL} or V _{IH}	- 55	-	30	60	mA
			- 70	-	20	50	mA
	I _{CC1}	Cycle time = 1μs CE# ≤ 0.2V and CE2 ≥ V _{CC} -0.2V I _{I/O} = 0mA Other pins at 0.2V or V _{CC} -0.2V	-	4	12	mA	
Standby Power Supply Current	I _{SB}	CE# = V _{IH} or CE2 = V _{IL} Other pins at V _{IL} or V _{IH}	-	0.15	2	mA	
			I _{SB1}	CE# ≥ V _{CC} -0.2V or CE2 ≤ 0.2V Other pins at 0.2V or V _{CC} -0.2V	LL	-	6
	LLI	-			6	50	μA

Notes:

- V_{IH}(max) = V_{CC} + 2.0V for pulse width less than 6ns.
- V_{IL}(min) = V_{SS} - 2.0V for pulse width less than 6ns.
- Over/Undershoot specifications are characterized, not 100% tested.
- Typical values are included for reference only and are not guaranteed or tested.
Typical values are measured at V_{CC} = V_{CC}(TYP.) and T_A = 25°C



CAPACITANCE (TA = 25°C, f = 1.0MHz)

PARAMETER	SYMBOL	MIN.	MAX	UNIT
Input Capacitance	C _{IN}	-	6	pF
Input/Output Capacitance	C _{I/O}	-	8	pF

Note : These parameters are guaranteed by device characterization, but not production tested.

AC TEST CONDITIONS

Input Pulse Levels	0.2V to V _{CC} - 0.2V
Input Rise and Fall Times	3ns
Input and Output Timing Reference Levels	1.5V
Output Load	C _L = 30pF + 1TTL, I _{OH} /I _{OL} = -1mA/2mA

AC ELECTRICAL CHARACTERISTICS

(1) READ CYCLE

PARAMETER	SYM.	LY62W51316-55		LY62W51316-70		UNIT
		MIN.	MAX.	MIN.	MAX.	
Read Cycle Time	t _{RC}	55	-	70	-	ns
Address Access Time	t _{AA}	-	55	-	70	ns
Chip Enable Access Time	t _{ACE}	-	55	-	70	ns
Output Enable Access Time	t _{OE}	-	30	-	35	ns
Chip Enable to Output in Low-Z	t _{CLZ} *	10	-	10	-	ns
Output Enable to Output in Low-Z	t _{OLZ} *	5	-	5	-	ns
Chip Disable to Output in High-Z	t _{CHZ} *	-	20	-	25	ns
Output Disable to Output in High-Z	t _{OHZ} *	-	20	-	25	ns
Output Hold from Address Change	t _{OH}	10	-	10	-	ns
LB#, UB# Access Time	t _{BA}	-	55	-	70	ns
LB#, UB# to High-Z Output	t _{BHZ} *	-	25	-	30	ns
LB#, UB# to Low-Z Output	t _{B LZ} *	10	-	10	-	ns

(2) WRITE CYCLE

PARAMETER	SYM.	LY62W51316-55		LY62W51316-70		UNIT
		MIN.	MAX.	MIN.	MAX.	
Write Cycle Time	t _{WC}	55	-	70	-	ns
Address Valid to End of Write	t _{AW}	50	-	60	-	ns
Chip Enable to End of Write	t _{CW}	50	-	60	-	ns
Address Set-up Time	t _{AS}	0	-	0	-	ns
Write Pulse Width	t _{WP}	45	-	55	-	ns
Write Recovery Time	t _{WR}	0	-	0	-	ns
Data to Write Time Overlap	t _{DW}	25	-	30	-	ns
Data Hold from End of Write Time	t _{DH}	0	-	0	-	ns
Output Active from End of Write	t _{OW} *	5	-	5	-	ns
Write to Output in High-Z	t _{WHZ} *	-	20	-	25	ns
LB#, UB# Valid to End of Write	t _{BW}	45	-	60	-	ns

*These parameters are guaranteed by device characterization, but not production tested.

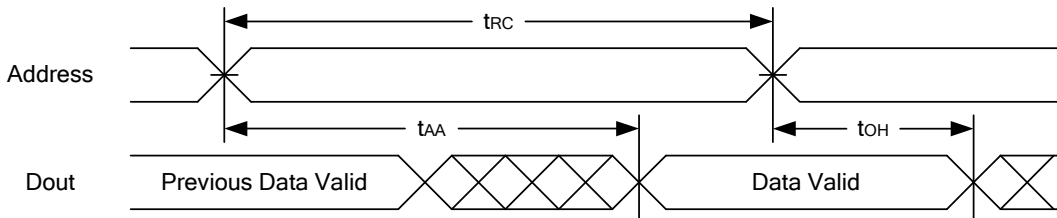
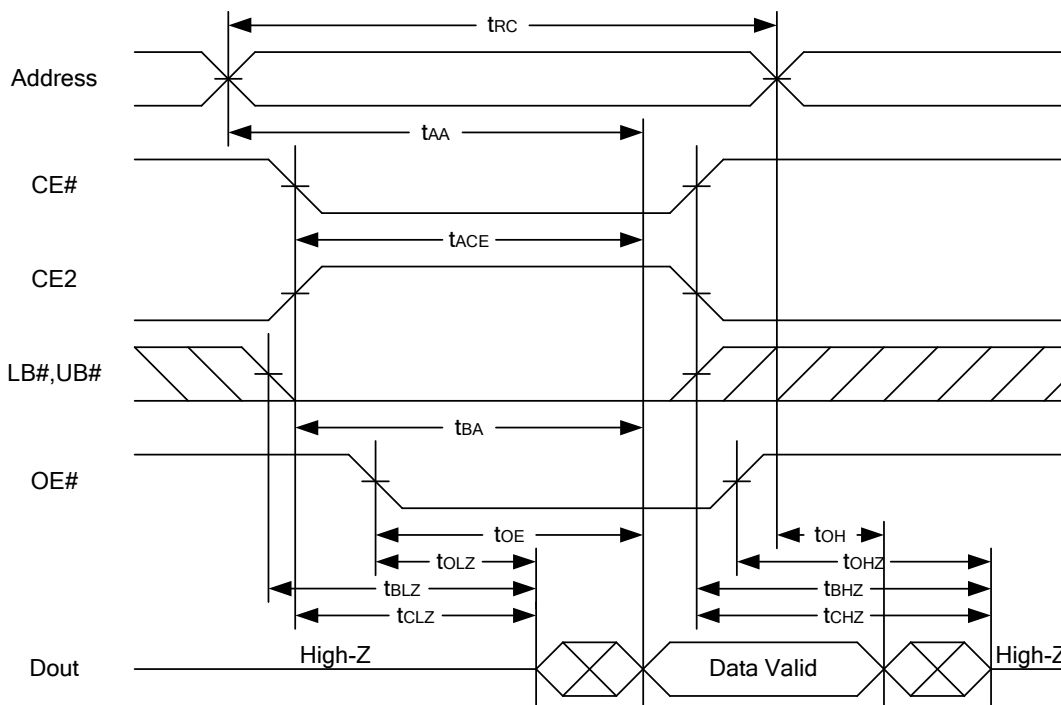
TIMING WAVEFORMS
READ CYCLE 1 (Address Controlled) (1,2)

READ CYCLE 2 (CE# and CE2 and OE# Controlled) (1,3,4,5)

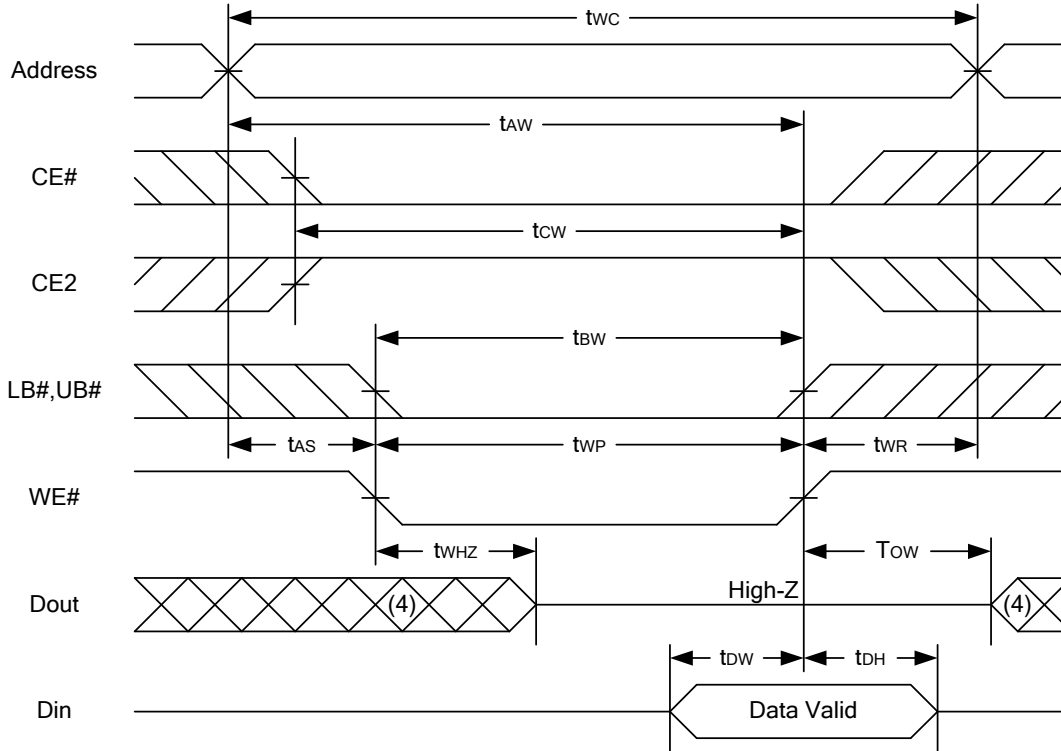
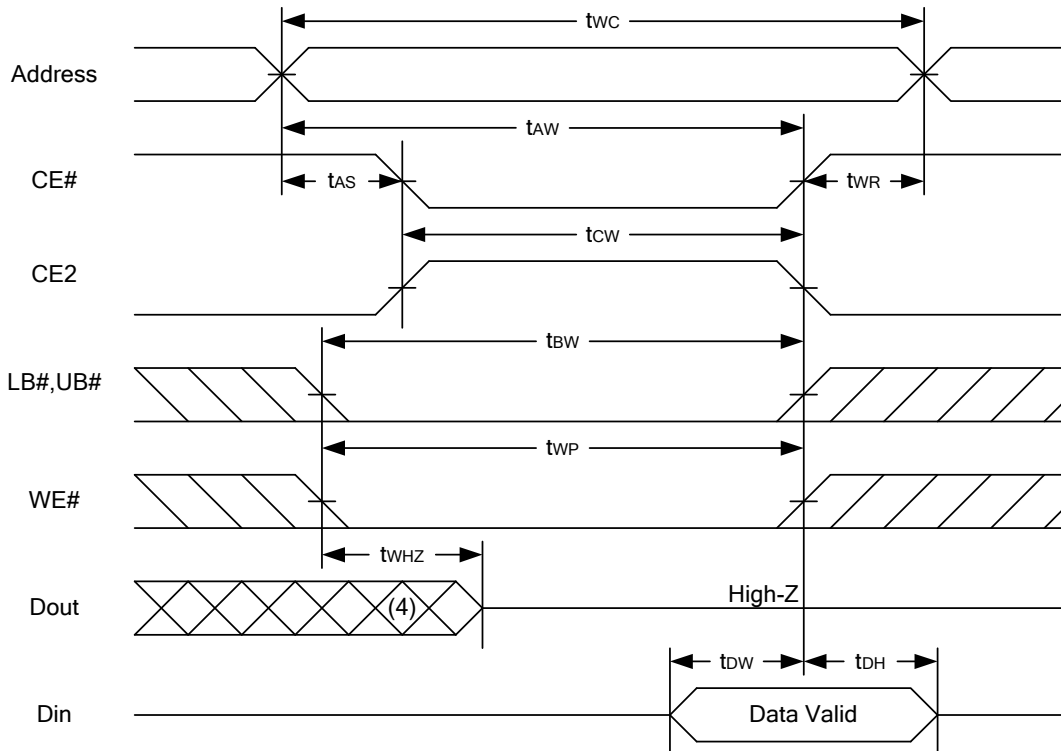
Notes :

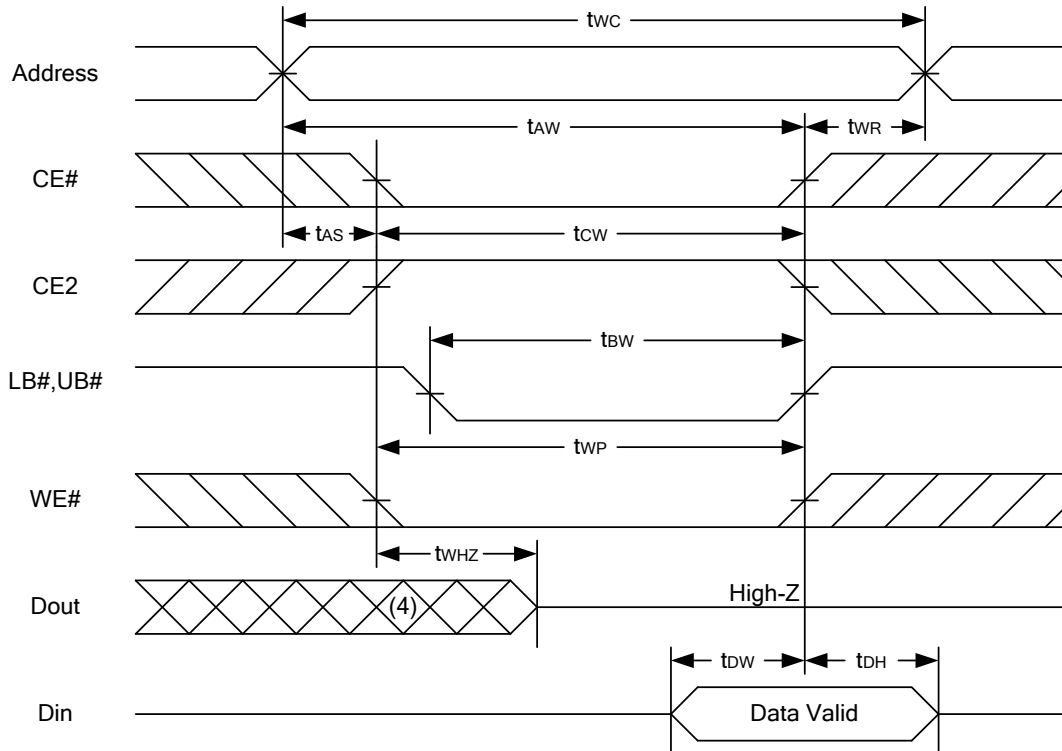
1. WE# is high for read cycle.
2. Device is continuously selected OE# = low, CE# = low, CE2 = high, LB# or UB# = low.
3. Address must be valid prior to or coincident with CE# = low, CE2 = high, LB# or UB# = low transition; otherwise t_{AA} is the limiting parameter.
4. t_{CLZ} , t_{BLZ} , t_{OLZ} , t_{CHZ} , t_{BHZ} and t_{OHZ} are specified with $C_L = 5pF$. Transition is measured $\pm 500mV$ from steady state.
5. At any given temperature and voltage condition, t_{CHZ} is less than t_{CLZ} , t_{BHZ} is less than t_{BLZ} , t_{OHZ} is less than t_{OLZ} .

WRITE CYCLE 1 (WE# Controlled) (1,2,4,5)

WRITE CYCLE 2 (CE# and CE2 Controlled) (1,4,5)

WRITE CYCLE 3 (LB#,UB# Controlled) (1,4,5)

Notes :

1. A write occurs during the overlap of a low CE#, high CE2, low WE#, LB# or UB# = low.
2. During a WE# controlled write cycle with OE# low, tWP must be greater than tWHZ + tDW to allow the drivers to turn off and data to be placed on the bus.
3. During this period, I/O pins are in the output state, and input signals must not be applied.
4. If the CE#, LB#, UB# low transition and CE2 high transition occurs simultaneously with or after WE# low transition, the outputs remain in a high impedance state.
5. tOW and tWHZ are specified with CL = 5pF. Transition is measured ±500mV from steady state.

DATA RETENTION CHARACTERISTICS

PARAMETER	SYMBOL	TEST CONDITION	MIN.	TYP.	MAX.	UNIT	
V _{CC} for Data Retention	V _{DR}	CE# ≥ V _{CC} - 0.2V or CE2 ≤ 0.2V	1.5	-	5.5	V	
Data Retention Current	I _{DR}	V _{CC} = 1.5V CE# ≥ V _{CC} -0.2V or CE2 ≤ 0.2V Other pins at 0.2V or V _{CC} -0.2V	LL	-	4	30	μA
			LLI	-	4	50	μA
Chip Disable to Data Retention Time	t _{CDR}	See Data Retention Waveforms (below)	0	-	-	ns	
Recovery Time	t _R		t _{RC} *	-	-	ns	

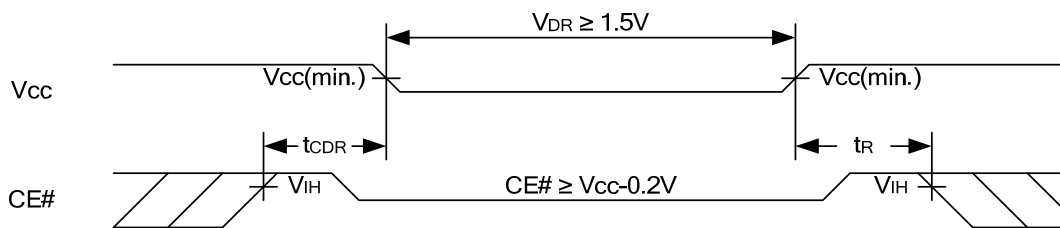
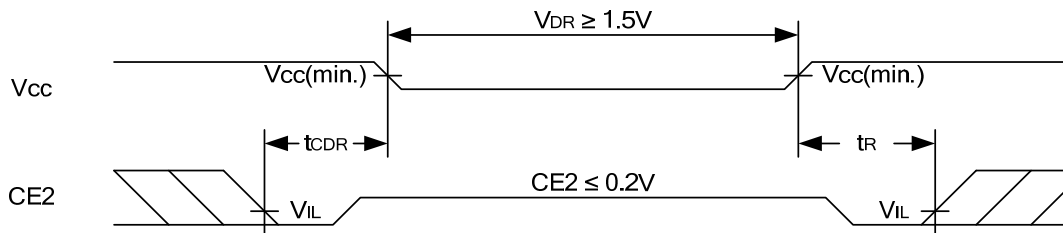
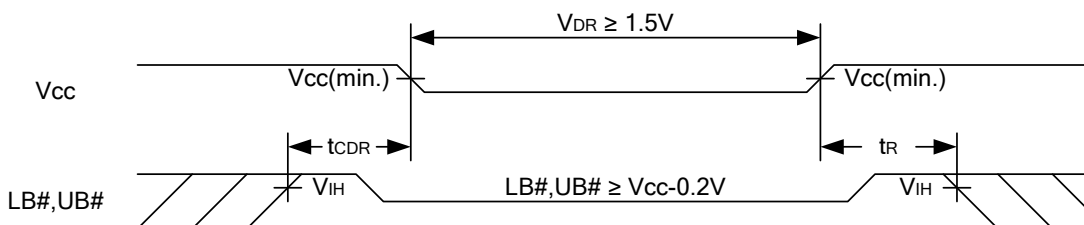
 t_{RC}* = Read Cycle Time

DATA RETENTION WAVEFORM
Low V_{CC} Data Retention Waveform (1) (CE# controlled)

Low V_{CC} Data Retention Waveform (2) (CE2 controlled)

Low V_{CC} Data Retention Waveform (3) (LB#, UB# controlled)

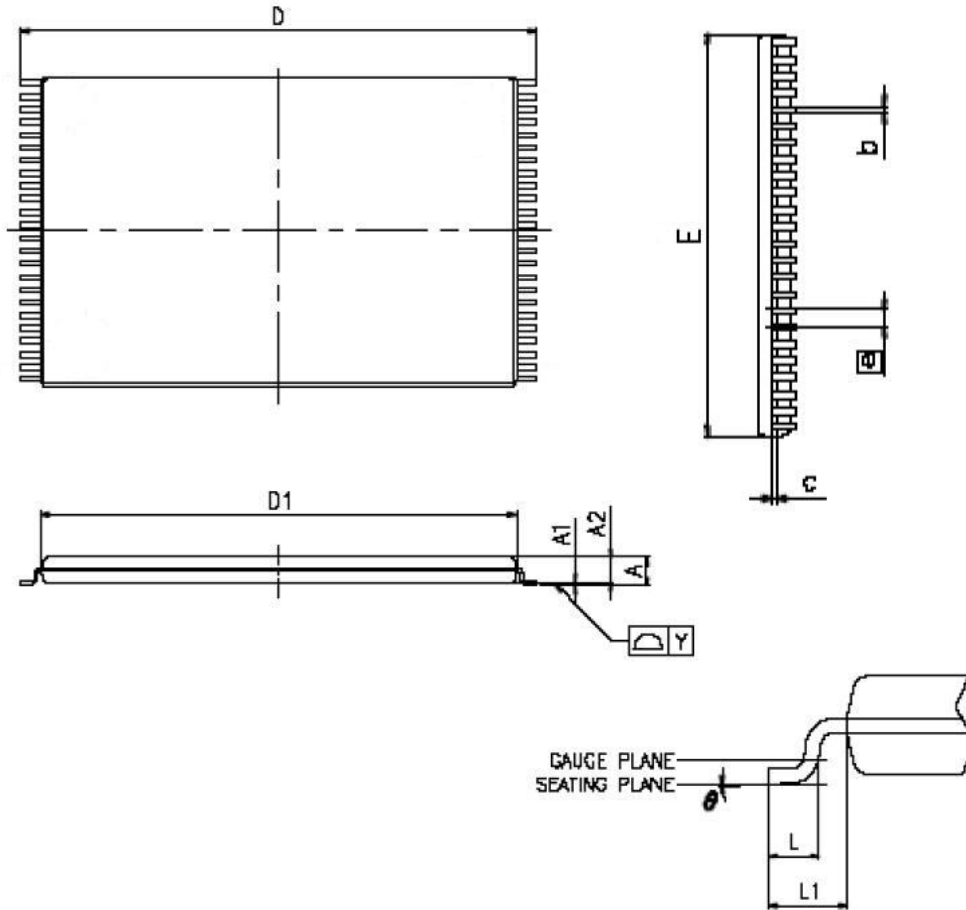
PACKAGE OUTLINE DIMENSION

48-pin 12mm x 20mm TSOP-I Package Outline



Dimension

VARIATIONS (ALL DIMENSIONS SHOWN IN MM)

SYMBOLS	MIN.	NOM.	MAX
A	-	-	1.20
A1	0.05	-	0.15
A2	0.95	1.00	1.05
b	0.17	0.22	0.27
c	0.10	-	0.21
□	19.80	20.00	20.20
□1	18.30	18.40	18.50
E	11.90	12.00	12.10
⊖	0.50 BASIC		
L	0.50	0.60	0.70
L1	-	0.80	-
Y	-	-	0.10
∅	∅	-	5°

NOTES:

- 1 JEDEC OUTLINE : MO-142 DD
2. PROFILE TOLERANCE ZONES FOR D1 AND E DO NOT INCLUDE MOLD PROTRUSION. ALLOWABLE MOLD PROTRUSION ON E IS 0.15mm PER SIDE AND ON D1 IS 0.25mm PER SIDE.
3. DIMENSION b DOES NOT INCLUDE DAMBAR PROTRUSION. ALLOWABLE DAMBAR PROTRUSION SHALL BE 0.08mm TOTAL IN EXCESS OF THE b DIMENSION AT MAXIMUM MATERIAL CONDITION. DAMBAR CANNOT BE LOCATED ON THE LOWER RADIUS OR THE FOOT.

48-ball 6mm × 8mm TFBGA Package Outline Dimension

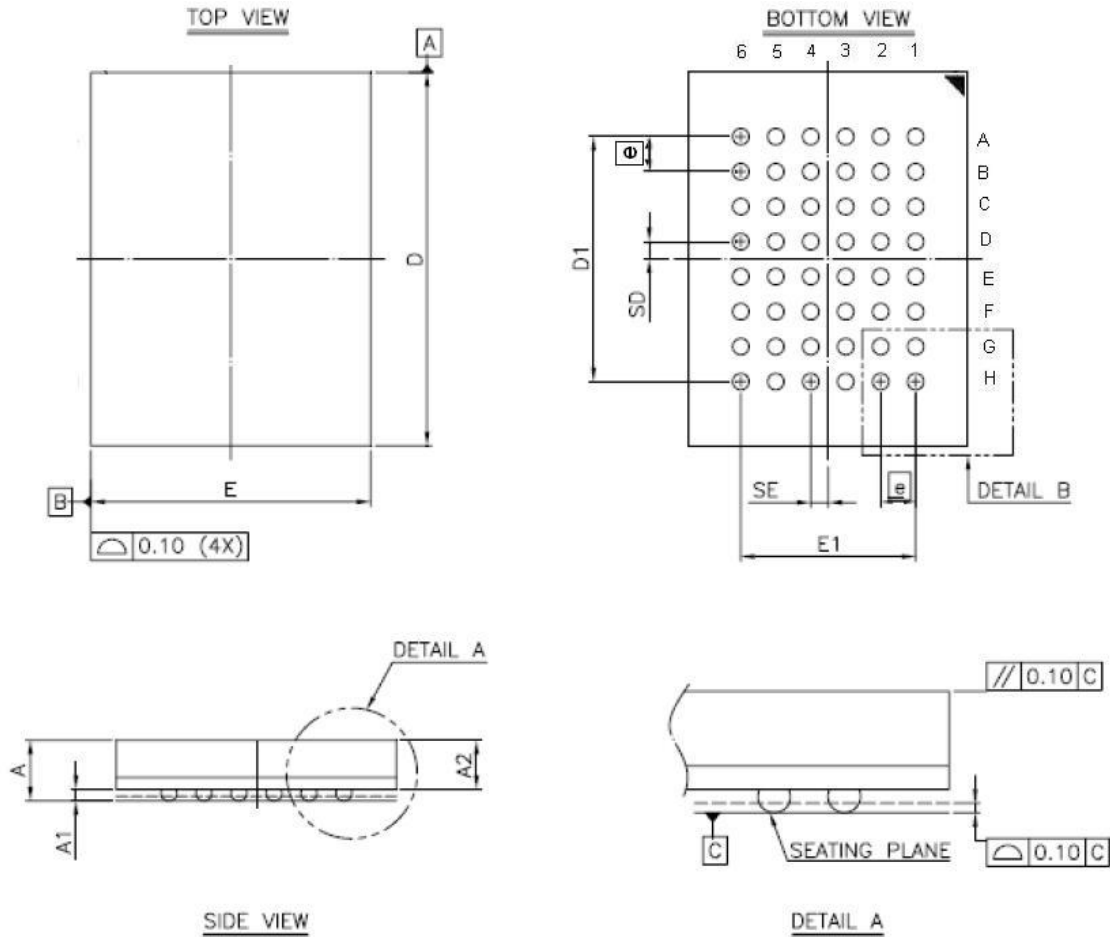

SYM.	DIMENSION (mm)			DIMENSION (inch)		
	MIN.	NOM.	MAX.	MIN.	NOM.	MAX.
A	—	—	1.40	—	—	0.055
A1	0.20	0.25	0.30	0.008	0.010	0.012
A2	—	—	1.05	—	—	0.041
b	0.30	0.35	0.40	0.012	0.014	0.016
D	7.95	8.00	8.05	0.313	0.315	0.317
D1	5.25 BSC			0.207 BSC		
E	5.95	6.00	6.05	0.234	0.236	0.238
E1	3.75 BSC			0.148 BSC		
SE	0.375 TYP			0.015 TYP		
SD	0.375 TYP			0.015 TYP		
\square	0.75 BSC			0.030 BSC		

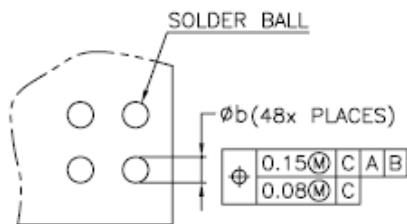

DETAIL B

NOTE:

1. CONTROLLING DIMENSION : MILLIMETER.
2. REFERENCE DOCUMENT : JEDEC MO-207.

ORDERING INFORMATION

[Production Status: M/P]

Package Type	Access Time (Speed)(ns)	Power Type	Temperature Range(°C)	Packing Type	Lyontek Item No.
48Pin12mmx20mm TSOP-I	55	Ultra Low Power	0°C~70°C	Tray	LY62W51316LL-55LL
				Tape Reel	LY62W51316LL-55LLT
			-40°C~85°C	Tray	LY62W51316LL-55LLI
				Tape Reel	LY62W51316LL-55LLIT
	70	Ultra Low Power	0°C~70°C	Tray	LY62W51316LL-70LL
				Tape Reel	LY62W51316LL-70LLT
			-40°C~85°C	Tray	LY62W51316LL-70LLI
				Tape Reel	LY62W51316LL-70LLIT

ORDERING INFORMATION
[Production Status: M/P]

Package Type	Access Time (Speed)(ns)	Power Type	Temperature Range(°C)	Packing Type	Lyontek Item No.
48-ball 6mmx8mm TFBGA	55	Ultra Low Power	0°C~70°C	Tray	LY62W51316GL-55LL
				Tape Reel	LY62W51316GL-55LLT
			-40°C~85°C	Tray	LY62W51316GL-55LLI
				Tape Reel	LY62W51316GL-55LLIT
	70	Ultra Low Power	0°C~70°C	Tray	LY62W51316GL-70LL
				Tape Reel	LY62W51316GL-70LLT
			-40°C~85°C	Tray	LY62W51316GL-70LLI
				Tape Reel	LY62W51316GL-70LLIT

ORDERING INFORMATION

 [Production Status: **EOL**]

Power Type : Special Ultra Low Power

Package Type	Access Time (Speed)(ns)	Temperature Range(°C)	Packing Type	EOL Item No.	Substitute Product
48Pin12mmx20mm TSOP-I	55	0°C~70°C	Tray	LY62W51316LL-55SL	LY62W51316BLL-45SL
			Tape Reel	LY62W51316LL-55SLT	LY62W51316BLL-45SLT
		-40°C~85°C	Tray	LY62W51316LL-55SLI	LY62W51316BLL-45SLI
			Tape Reel	LY62W51316LL-55SLIT	LY62W51316BLL-45SLIT
	70	0°C~70°C	Tray	LY62W51316LL-70SL	LY62W51316BLL-45SL
			Tape Reel	LY62W51316LL-70SLT	LY62W51316BLL-45SLT
		-40°C~85°C	Tray	LY62W51316LL-70SLI	LY62W51316BLL-45SLI
			Tape Reel	LY62W51316LL-70SLIT	LY62W51316BLL-45SLIT

ORDERING INFORMATION

[Production Status: **EOL**]

Power Type : Special Ultra Low Power

Package Type	Access Time (Speed)(ns)	Temperature Range(°C)	Packing Type	EOL Item No.	Substitute Product
48-ball 6mmx8mm TFBGA	55	0°C~70°C	Tray	LY62W51316GL-55SL	LY62W51316BGL-45SL
			Tape Reel	LY62W51316GL-55SLT	LY62W51316BGL-45SLT
		-40°C~85°C	Tray	LY62W51316GL-55SLI	LY62W51316BGL-45SLI
			Tape Reel	LY62W51316GL-55SLIT	LY62W51316BGL-45SLIT
	70	0°C~70°C	Tray	LY62W51316GL-70SL	LY62W51316BGL-45SL
			Tape Reel	LY62W51316GL-70SLT	LY62W51316BGL-45SLT
		-40°C~85°C	Tray	LY62W51316GL-70SLI	LY62W51316BGL-45SLI
			Tape Reel	LY62W51316GL-70SLIT	LY62W51316BGL-45SLIT



Lyontek Inc.

LY62W51316

Rev. 2.0

512K X 16 BIT LOW POWER CMOS SRAM

THIS PAGE IS LEFT BLANK INTENTIONALLY.